



Voltage Regulator TAPCON[®] 230 pro

Operating Instructions

3550953/02 EN



© All rights reserved by Maschinenfabrik Reinhausen

Dissemination and reproduction of this document and use and disclosure of its content are strictly prohibited unless expressly permitted.

Infringements will result in liability for compensation. All rights reserved in the event of the granting of patents, utility models or designs.

The product may have been altered since this document was published.

We reserve the right to change the technical data, design and scope of supply.

Generally the information provided and agreements made when processing the individual quotations and orders are binding.

The original operating instructions were written in German.



Table of contents

1 Introduction..... 8

1.1 Manufacturer..... 8

1.2 Subject to change without notice..... 8

1.3 Completeness..... 8

1.4 Safekeeping..... 8

1.5 Notation conventions..... 8

1.5.1 Hazard communication system..... 9

1.5.2 Information system..... 10

1.5.3 Instruction system..... 10

1.5.4 Typographic conventions..... 11

2 Safety..... 12

2.1 General safety information..... 12

2.2 Appropriate use..... 12

2.3 Inappropriate use..... 12

2.4 Personnel qualification..... 12

2.5 Operator's duty of care..... 13

3 IT security..... 14

4 Product description..... 15

4.1 Scope of delivery..... 15

4.2 Function description of the voltage regulation..... 16

4.3 Performance features..... 17

4.4 Operating modes..... 18

4.5 Hardware..... 19

4.5.1 Name plate..... 20

4.5.2 Operating controls..... 20

4.5.3 Display elements..... 22

4.5.4 Serial interface..... 24

4.5.5 Modules..... 24

5 Packaging, transport and storage..... 27

5.1 Packaging..... 27

5.1.1 Purpose..... 27

5.1.2 Suitability, structure and production..... 27



5.1.3 Markings..... 27

5.2 Transportation, receipt and handling of shipments..... 27

5.3 Storage of shipments..... 29

6 Mounting 30

6.1 Preparation 30

6.2 Mounting device..... 30

6.2.1 Flush panel mounting..... 32

6.2.2 Wall mounting with mounting brackets..... 33

6.2.3 Cap rail mounting 34

6.2.4 Wall mounting 35

6.2.5 Removing the door..... 36

6.3 Connecting device 37

6.3.1 Cable recommendation 38

6.3.2 Information about laying fiber-optic cable 39

6.3.3 Electromagnetic compatibility..... 39

6.3.4 Connecting cables to the system periphery 44

6.3.5 Supplying the voltage regulator using auxiliary voltage 44

6.3.6 Wiring device..... 44

6.3.7 Checking functional reliability 45

7 Commissioning..... 47

7.1 Setting the display contrast..... 47

7.2 Setting parameters 47

7.2.1 Setting the language 48

7.2.2 Setting further parameters 48

7.3 Calibrating the analog input 49

7.4 Function tests 50

7.4.1 Checking control functions 51

7.4.2 Checking additional functions 52

7.4.3 Checking parallel operation..... 55

8 Operation..... 60

8.1 Key lock 60

8.2 General 60

8.2.1 Setting device ID 60

8.2.2 Setting the baud rate..... 61

8.2.3 Setting the switching pulse time..... 61



8.2.4 Setting operations counter 63

8.2.5 Dimming display 64

8.2.6 Activating/deactivating the automatic key lock 64

8.2.7 "Function monitoring" message for monitoring messages <30 V 65

8.2.8 Setting motor runtime monitoring 66

8.2.9 Activate manual mode/auto mode 68

8.2.10 Activating Local/Remote 69

8.2.11 Setting the COM1 password 69

8.2.12 Setting the password duration 70

8.3 NORMset 70

8.4 Control parameters 72

8.4.1 Setting desired value 1...3 74

8.4.2 Selecting a desired value 75

8.4.3 Bandwidth 76

8.4.4 Setting delay time T1 77

8.4.5 Setting control response T1 78

8.4.6 Setting delay time T2 79

8.5 Limit values 80

8.5.1 Setting undervoltage monitoring $U<$ 80

8.5.2 Setting overvoltage monitoring $U>$ 83

8.5.3 Setting overcurrent monitoring $I>$ 85

8.5.4 Set undercurrent monitoring $I<$ 86

8.5.5 Activate/deactivate active power monitoring 87

8.5.6 Permitted tap positions 87

8.6 Compensation 89

8.6.1 Line drop compensation 89

8.6.2 Z compensation 92

8.7 Transformer data 94

8.7.1 Setting the primary transformer voltage 95

8.7.2 Setting the secondary transformer voltage 95

8.7.3 Setting primary transformer current 96

8.7.4 Setting the current transformer connection 96

8.7.5 Setting the phase difference for the current transformer/voltage transformer 97

8.8 Parallel operation 101

8.8.1 Assigning CAN bus address 102

8.8.2 Selecting parallel operation method 102

8.8.3 Assigning a parallel operation group 106



- 8.8.4 Activating/deactivating blocking in simplex mode 107
- 8.8.5 Setting delay time for parallel operation error messages 107
- 8.8.6 Configuring the maximum permitted tap difference 108
- 8.8.7 Activating/deactivating follower tapping without measured voltage 108
- 8.8.8 Activating/deactivating parallel operation 109
- 8.9 Tap position capture 109
 - 8.9.1 Digital tap position capture 109
 - 8.9.2 Analog tap position capture 110
- 8.10 Setting the desired voltage level remotely 113
 - 8.10.1 Activate/deactivate setting the desired voltage level remotely 113
 - 8.10.2 Setting lower limit value for the desired value 114
 - 8.10.3 Setting upper limit value for the desired value 115
- 8.11 Configurable inputs and outputs 116
 - 8.11.1 Linking inputs with functions 116
 - 8.11.2 Linking outputs with functions 118
- 8.12 LED selection 120
- 8.13 Information about device 122
 - 8.13.1 Displaying info screen 122
 - 8.13.2 Displaying measured values 122
 - 8.13.3 Display calculated values 123
 - 8.13.4 Carrying out LED test 124
 - 8.13.5 Displaying status of the MIO card 124
 - 8.13.6 Displaying status of the PIO card 125
 - 8.13.7 Displaying parallel operation 126
 - 8.13.8 Displaying data on CAN bus 127
 - 8.13.9 Peak memory 127
 - 8.13.10 Resetting parameters 128
 - 8.13.11 Displaying memory overview 129
 - 8.13.12 Displaying event overview 129
- 9 Fault elimination 130**
 - 9.1 No regulation in AUTO mode 130
 - 9.2 Unexplained tap change 130
 - 9.3 Man-machine interface 131
 - 9.4 Incorrect measured values 131
 - 9.5 Parallel operation faults 132
 - 9.6 Tap position capture incorrect 132



9.7	Customized GPIs/GPOs	133
9.8	General faults	133
9.9	Other faults	134
10	Messages	135
11	Disposal.....	137
12	Overview of parameters.....	138
13	Technical data.....	142
13.1	Display elements	142
13.2	Electrical data	142
13.3	Dimensions and weight.....	142
13.4	Ambient conditions	144
13.5	Electrical safety.....	144
13.6	Electromagnetic compatibility	145
13.7	Environmental durability tests.....	145
13.8	Mechanical stability.....	145
	Glossary	146
	List of key words	147



1 Introduction

This technical file contains detailed descriptions on the safe and proper installation, connection, commissioning and monitoring of the product.

It also includes safety instructions and general information about the product.

This technical file is intended solely for specially trained and authorized personnel.

1.1 Manufacturer

The product is manufactured by:

Maschinenfabrik Reinhausen GmbH

Falkensteinstraße 8
93059 Regensburg, Germany
Tel.: (+49) 9 41/40 90-0
Fax: (+49) 9 41/40 90-7001
E-mail: sales@reinhausen.com

Further information on the product and copies of this technical file are available from this address if required.

1.2 Subject to change without notice

The information contained in this technical file comprises the technical specifications approved at the time of printing. Significant modifications will be included in a new edition of the technical file.

The document number and version number of this technical file are shown in the footer.

1.3 Completeness

This technical file is incomplete without the supporting documentation.

1.4 Safekeeping

Keep this technical file and all supporting documents ready at hand and accessible for future use at all times.

1.5 Notation conventions

This section contains an overview of the symbols and textual emphasis used.

1.5.1 Hazard communication system

Warnings in this technical file are displayed as follows.

1.5.1.1 Warning relating to section

Warnings relating to sections refer to entire chapters or sections, sub-sections or several paragraphs within this technical file. Warnings relating to sections use the following format:

▲ WARNING



Type of danger!

Source of the danger and outcome.

- ▶ Action
- ▶ Action

1.5.1.2 Embedded warning information

Embedded warnings refer to a particular part within a section. These warnings apply to smaller units of information than the warnings relating to sections. Embedded warnings use the following format:

▲ DANGER! Instruction for avoiding a dangerous situation.

1.5.1.3 Signal words and pictograms

The following signal words are used:

Signal word	Meaning
DANGER	Indicates a hazardous situation which, if not avoided, will result in death or serious injury.
WARNING	Indicates a hazardous situation which, if not avoided, could result in death or serious injury.
CAUTION	Indicates a hazardous situation which, if not avoided, could result in injury.
NOTICE	Indicates measures to be taken to prevent damage to property.

Table 1: Signal words in warning notices

Pictograms warn of dangers:





Pictogram	Meaning
	Warning of a danger point
	Warning of dangerous electrical voltage
	Warning of combustible substances
	Warning of danger of tipping

Table 2: Pictograms used in warning notices

1.5.2 Information system

Information is designed to simplify and improve understanding of particular procedures. In this technical file it is laid out as follows:



Important information.

1.5.3 Instruction system

This technical file contains single-step and multi-step instructions.

Single-step instructions

Instructions which consist of only a single process step are structured as follows:

Aim of action

✓ Requirements (optional).

▶ Step 1 of 1.

⇒ Result of step (optional).

⇒ Result of action (optional).



Multi-step instructions

Instructions which consist of several process steps are structured as follows:

Aim of action

✓ Requirements (optional).

1. Step 1.

⇒ Result of step (optional).

2. Step 2.

⇒ Result of step (optional).

⇒ Result of action (optional).

1.5.4 Typographic conventions

The following typographic conventions are used in this technical file:

Typographic convention	Purpose	Example
UPPERCASE	Operating controls, switches	ON/OFF
[Brackets]	PC keyboard	[Ctrl] + [Alt]
Bold	Software operating controls	Press Continue button
...>...>...	Menu paths	Parameter > Control parameter
<i>Italics</i>	System messages, error messages, signals	<i>Function monitoring alarm triggered</i>
[▶ Number of pages].	Cross reference	[▶ 41].

Table 3: Typographic conventions



2 Safety

2.1 General safety information

The technical file contains detailed descriptions on the safe and proper installation, connection, commissioning and monitoring of the product.

- Read this technical file through carefully to familiarize yourself with the product.
- Particular attention should be paid to the information given in this chapter.

2.2 Appropriate use

If used as intended and in compliance with the requirements and conditions specified in this technical document as well as with the warnings in this technical document and attached to the product, then the product does not present any danger to people, property or the environment. This applies throughout the product's entire life, from delivery through installation and operation to disassembly and disposal.

The operational quality-assurance system ensures a consistently high quality standard, particularly in regard to the observance of health and safety requirements.

The following is considered appropriate use

- The product must be operated in accordance with this technical file and the agreed delivery conditions and technical data
- The equipment and special tools supplied must be used solely for the intended purpose and in accordance with the specifications of this technical file

2.3 Inappropriate use

Use is considered to be inappropriate if the product is used other than as described in the Appropriate use section. Please also note the following:

- Risk of explosion and fire from highly flammable or explosive gases, vapors, or dusts. Do not operate product in areas at risk of explosion.
- Unauthorized or inappropriate changes to the product may lead to personal injury, material damage, and operational faults. Only modify product following discussion with Maschinenfabrik Reinhausen GmbH.

2.4 Personnel qualification

The product is designed solely for use in electrical energy systems and facilities operated by appropriately trained staff. This staff comprises people who are familiar with the installation, assembly, commissioning and operation of such products.



2.5 Operator's duty of care

To prevent accidents, disruptions and damage as well as unacceptable adverse effects on the environment, those responsible for transport, installation, operation, maintenance and disposal of the product or parts of the product must ensure the following:

- All warning and hazard notices are complied with.
- Personnel are instructed regularly in all relevant aspects of operational safety, the operating instructions and particularly the safety instructions contained therein.
- Regulations and operating instructions for safe working as well as the relevant instructions for staff procedures in the case of accidents and fires are kept on hand at all times and are displayed in the workplace where applicable.
- The product is only used when in a sound operational condition and safety equipment in particular is checked regularly for operational reliability.
- Only replacement parts, lubricants and auxiliary materials which are authorized by the manufacturer are used.
- The specified operating conditions and requirements of the installation location are complied with.
- All necessary devices and personal protective equipment for the specific activity are made available.
- The prescribed maintenance intervals and the relevant regulations are complied with.
- Installation, electrical connection and commissioning of the product may only be carried out by qualified and trained personnel in accordance with this technical file.
- The operator must ensure appropriate use of the product.



3 IT security

Observe the following recommendations to operate the product safely.

General

- Ensure that only authorized personnel have access to the device. Use the device door lock for this purpose.
- Only use the device within an ESP (electronic security perimeter). Do not connect the device to the Internet in an unprotected state.
- Ensure that the device is only operated by trained personnel who are familiar with IT security.
- Do not assign any passwords that are easy to guess. The password should consist of upper-case letters, lower-case letters and numbers and should be 8 characters long.

Commissioning

Observe the following recommendations for device commissioning:

- Set the password duration to 5 minutes or less [► Section 8.2.12, Page 70].
- Assign a password for the COM1 front interface [► Section 8.2.11, Page 69].

Operation

Observe the following recommendations during device operation:

- Do not leave the device unattended when the entered password is active. The password entered is active if the *Parallel operation* LED flashes.
- Change the password at regular intervals.

4 Product description

This chapter contains an overview of the design and function of the product.

4.1 Scope of delivery

The following components are included in the delivery:

- Voltage regulator TAPCON® 230
- Folder with all device documentation
- Quick reference guide (in the inside door of the device)
- Door key
- 3mm Allen key
- 2 countersunk head screws
- Control panel bracket pre-mounted on device's housing

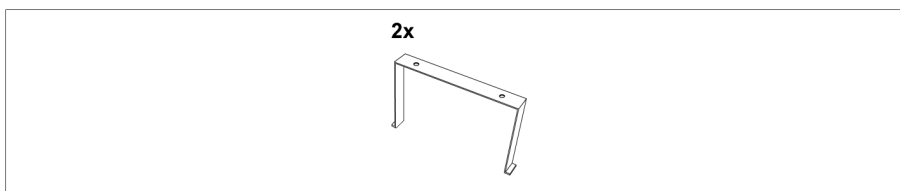

Figure 1: Control panel bracket

- Mounting bracket for wall mounting

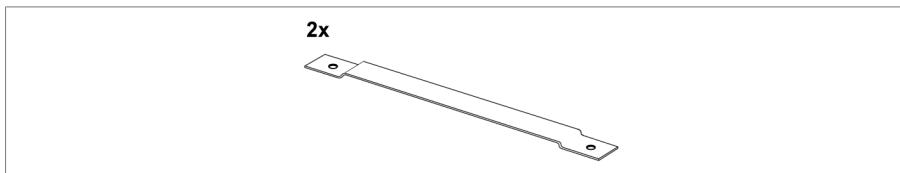

Figure 2: Mounting bracket

- Covering strip for door

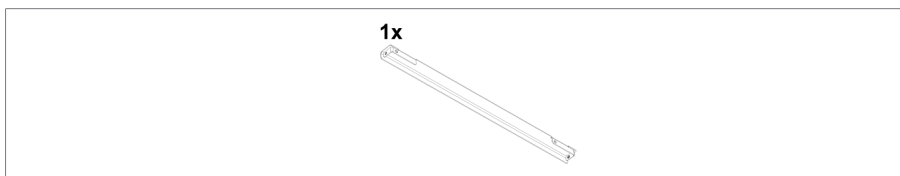

Figure 3: Covering strip

Optional:

- Cap rail clip

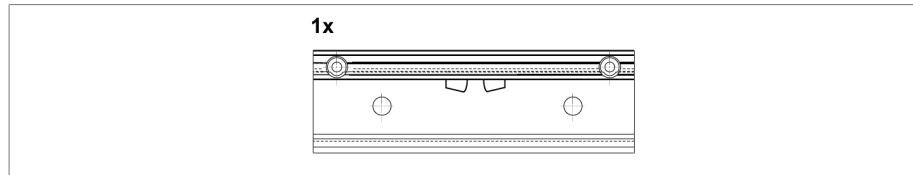

Figure 4: Cap rail clip

Please note the following:

- Check the shipment for completeness on the basis of the shipping documents.
- Store the parts in a dry place until installation.

4.2 Function description of the voltage regulation

The TAPCON® serves to keep constant the output voltage of a transformer with an on-load tap-changer.

The TAPCON® compares the transformer's measured voltage (U_{actual}) with a defined reference voltage (U_{desired}). The difference between U_{actual} and U_{desired} is the control deviation (dU).

The TAPCON® parameters can be optimally adjusted to the line voltage response to achieve a balanced control response with a small number of tap-change operations.

The following diagram shows an overview of voltage regulation.

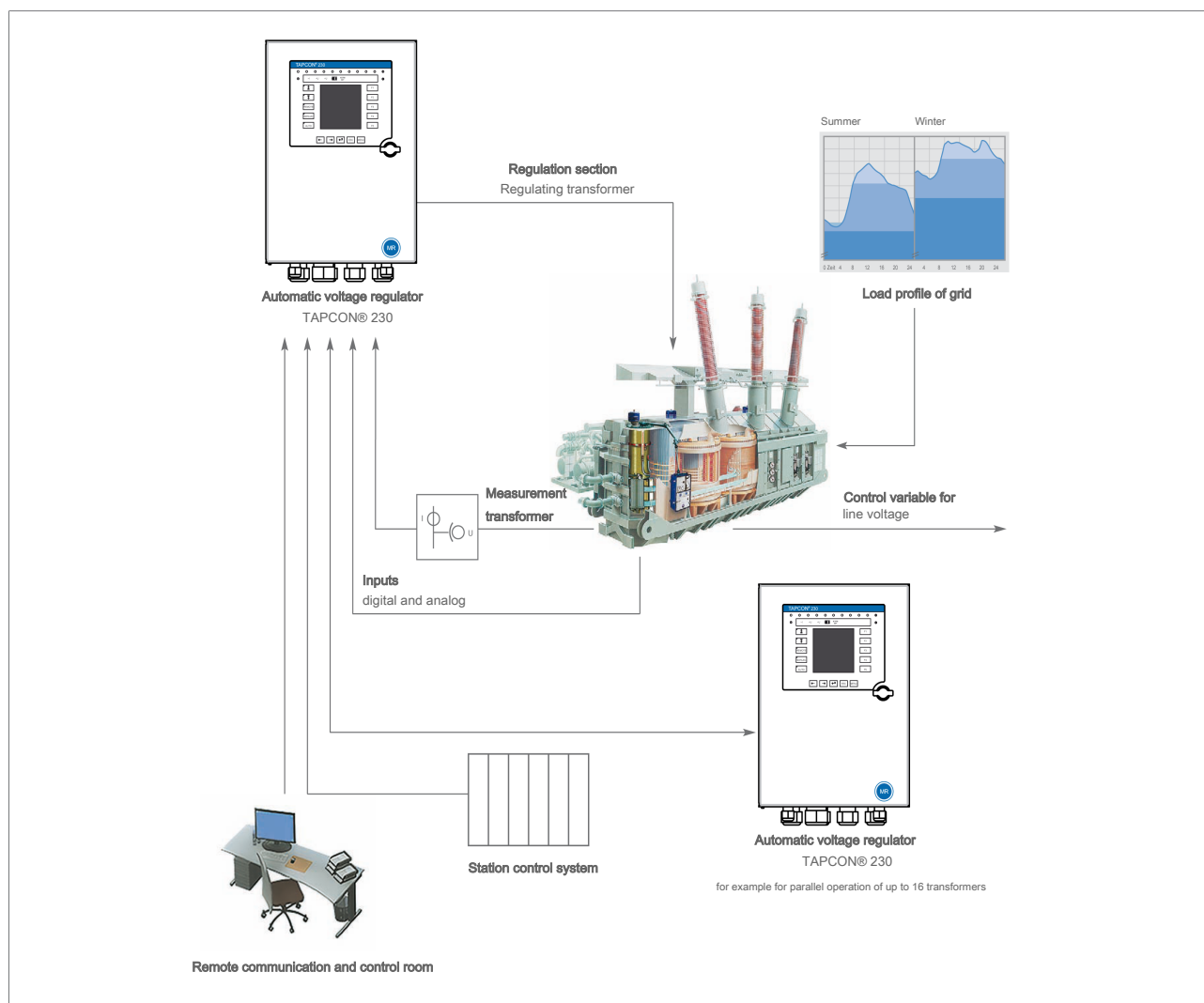

Figure 5: Overview of voltage regulation

4.3 Performance features

The TAPCON® is responsible for controlling tapped transformers.

Apart from control tasks, the TAPCON® provides additional functions such as:

- Integrated monitoring functions:
 - Undervoltage blocking and overvoltage blocking
 - Overvoltage detection with high-speed return
- Compensation for voltage drops on the line (line drop compensation)
- Compensation for voltage fluctuations in the meshed grid (Z compensation)



- Digital inputs and outputs can be individually programmed on-site by the customer
- Additional indicators using LEDs outside the display for freely selectable functions
- Display of all measured values such as voltage, current, active power, apparent power or reactive power, power factor ($\cos \varphi$)
- Selection of 3 different desired values
- You can select the tap position capture when ordering:
 - Using analog signal 4...20 mA
 - Using analog signal via resistor contact series
 - Using digital signal via BCD code
- Additional digital inputs and outputs which can be freely parameterized by the customer
- Parallel operation of up to 6 transformers in 2 groups using the following methods:
 - Master/follower
 - Circulating reactive current minimization

4.4 Operating modes

The device can be operated in the following operating modes:

Auto mode (AUTO)

In auto mode, the voltage is automatically controlled in accordance with the set parameters. You cannot change further device settings in auto mode. There is no active management by a higher level control system in this operating mode.





Manual mode (MANUAL)

In manual mode, there is no automatic control. The motor-drive unit can be controlled via the device's operating panel. You can change the device settings.

Local mode (LOCAL)

There is no active management by a superordinate control system in this operating mode.

Remote mode (REMOTE)

In remote mode, you can perform commands using an external control level. In this case, manual operation of the , ,  and  keys is disabled.

	AUTO + LOCAL	AUTO + REMOTE	MANUAL + LOCAL	MANUAL + REMOTE
Automatic regulation	Yes	Yes	No	No
Tap-change operation using operating controls	No	No	Yes	No
Tap-change operation using inputs	No	No	No	Yes

Table 4: Overview of operating modes

4.5 Hardware

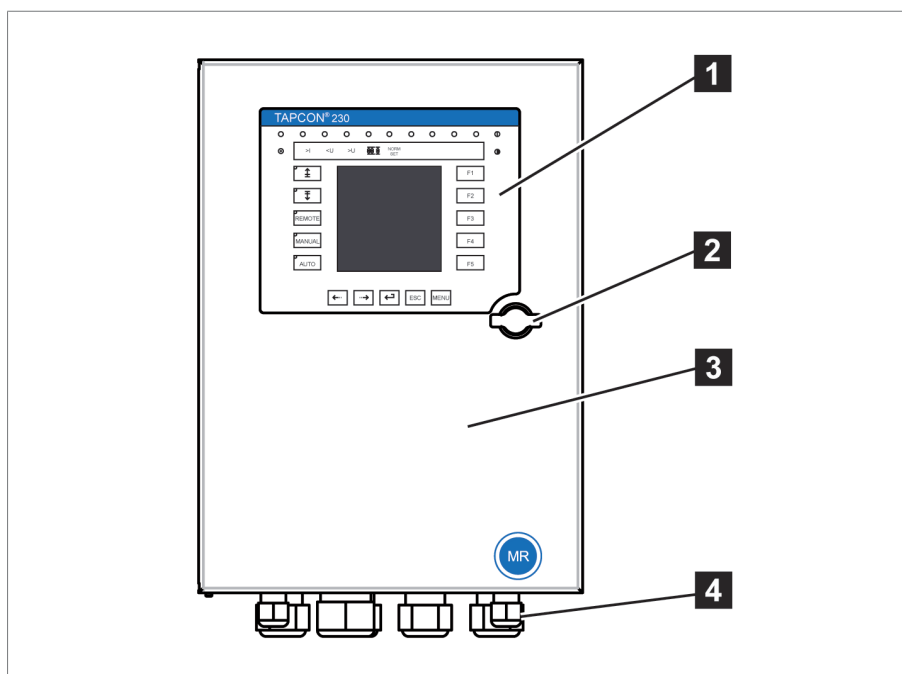

Figure 6: Hardware

1 Operating panel with display and LEDs	3 Door
2 Door lock	4 Metric cable glands

4.5.1 Name plate

The name plate is on the outside of the device:

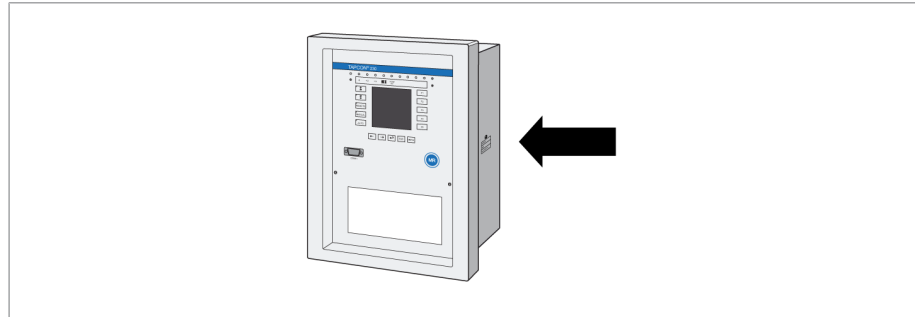

Figure 7: Name plate

4.5.2 Operating controls

The device has 15 pushbuttons. The illustration below is an overview of all the device's operating controls.

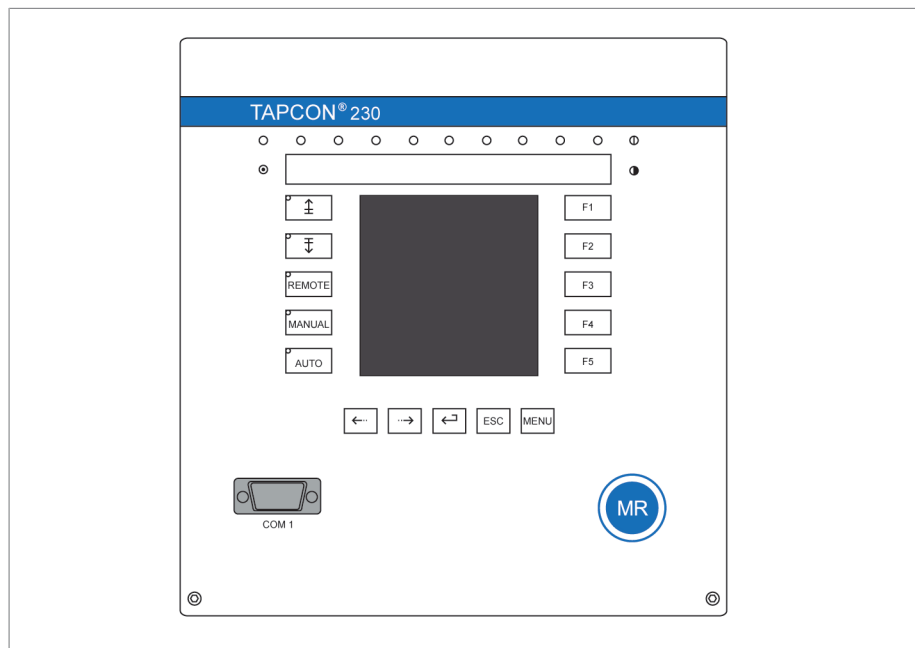

Figure 8: Operating controls



RAISE key: Sends control command for raise tap-change to the motor-drive unit in manual mode.











LOWER key: Sends control command for lower tap-change to the motor-drive unit in manual mode.



REMOTE key: Activate/deactivate "Remote" operating mode. When you deactivate this operating mode, the "Local" operating mode is automatically activated.



	MANUAL key: Activate "Manual mode" operating mode.
	AUTO key: Activate "Auto mode" operating mode.
	PREV key: Change measured value display and switch to previous parameters.
	NEXT key: Change measured value display and switch to next parameters.
	ENTER key: Confirm selection and save modified parameters.
	ESC key: Escape current menu and select previous menu levels.
	MENU key: Select main menu.
	F1 to F5 function keys: Select functions displayed on the screen.

4.5.3 Display elements

The device has a graphics display and 15 LEDs, which indicate the various operating statuses or events.

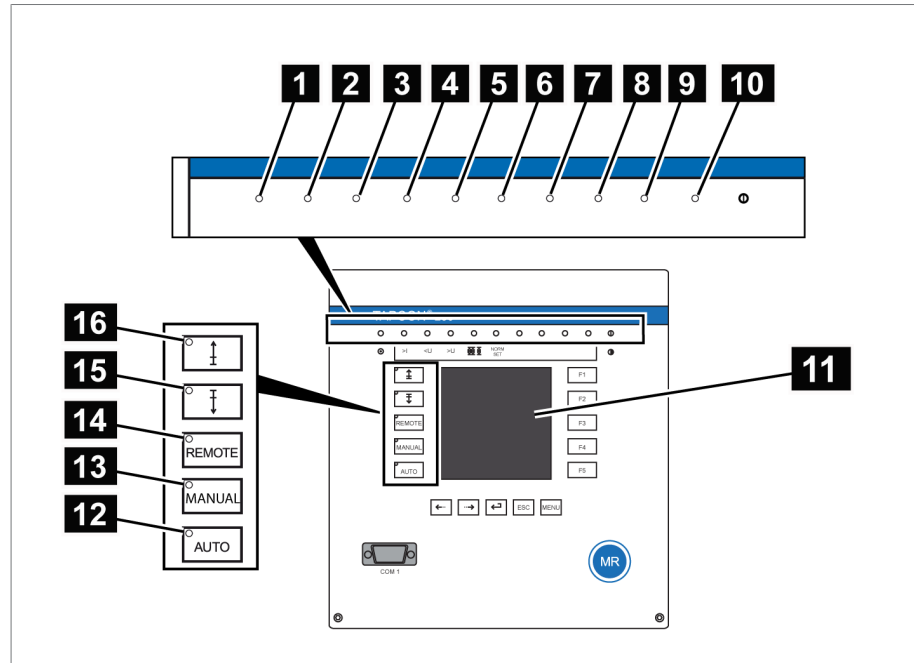

Figure 9: Indicator elements

1 <i>Operating status</i> LED, green	9 LED 3, function can be freely assigned, yellow/green
2 <i>Overcurrent blocking</i> LED, red	10 LED 4, function can be freely assigned, yellow/red
3 <i>Undervoltage blocking</i> LED, red	11 Graphics display
4 <i>Overvoltage blocking</i> LED, red	12 <i>Auto operating mode active</i> LED
5 <i>Parallel operation active</i> LED, green	13 <i>Manual operating mode active</i> LED
6 <i>NORMset active</i> LED, green	14 <i>Remote operating mode active</i> LED
7 LED 1, function can be freely assigned, yellow	15 <i>Lower tap-change active</i> LED
8 LED 2, function can be freely assigned, yellow	16 <i>Raise tap-change active</i> LED

Display

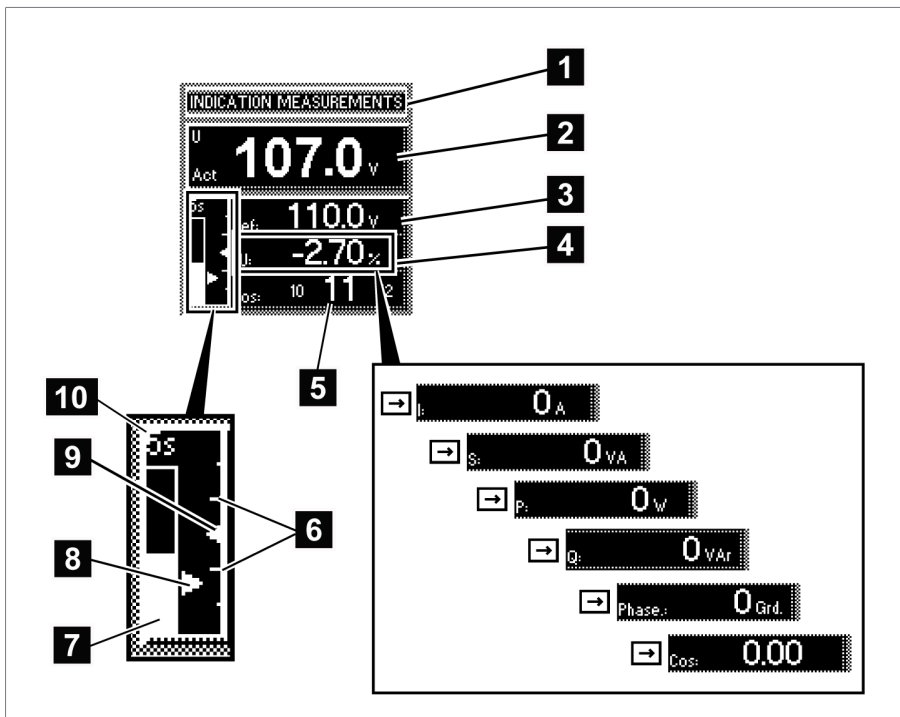

Figure 10: Display

1 Status line	6 Bandwidth (upper and lower limit)
2 Measured voltage U_{actual}	7 Time bar for delay time T1
3 Desired voltage $U_{desired}$	8 Mark for measured voltage U_{actual}
4 Other measured values (use \rightarrow or \leftarrow to switch between them)	9 Mark for desired voltage $U_{desired}$
5 Tap position n-1; n; n+1	10 Remaining delay time T1

Other measured values

In auto mode and manual mode the measured value display **4** can be set using the \rightarrow or \leftarrow keys. The following measured values can be displayed:

Unit	Measured value
dU	Control deviation
I	Current
S	Apparent power
P	Active power
Q	Reactive power
Phase	Phase angle
Cos	Active factor: Cosine ϕ [phi] (power factor)

Table 5: Measured value display

Status line Current messages and events are displayed in the status line **1**. You can find more information about messages and events in the Messages chapter.

4.5.4 Serial interface

The parameters for the device can be set using a PC. The COM 1 (RS232) serial interface on the front panel is provided for this purpose. You can use the connection cable supplied to establish a connection to your PC via the RS232 or USB port (using the optional USB adapter).

TAPCON®-trol software is needed for parameterization via the serial interface. The software and the associated user guide can be downloaded from www.reinhausen.com.

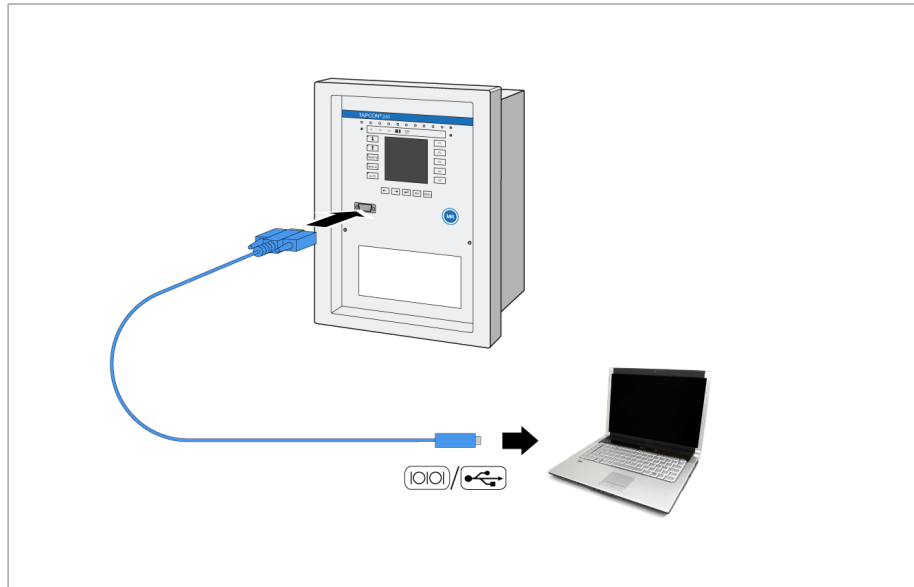

Figure 11: Device connection to a PC

4.5.5 Modules

The device has integrated modules:

- MIO card
- PIO card

Carry out wiring in accordance with the supplied connection diagram. The relevant cards are described in the following sections.

4.5.5.1 MIO card

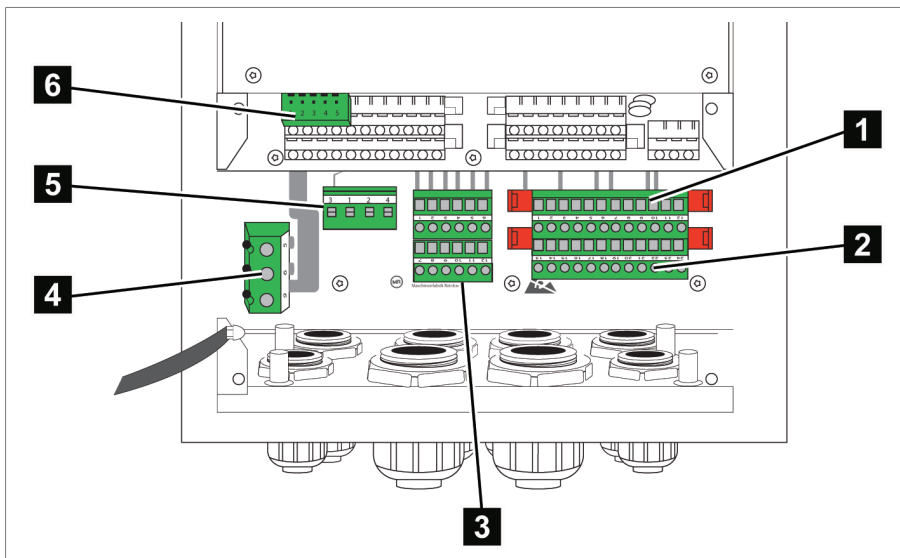

Figure 12: MIO card

1 Relay outputs (terminal X4)	4 Current transformer connection (terminal X1)
2 Signal inputs (terminal X4)	5 Voltage transformer connection and network connection (terminal X2)
3 Relay outputs (terminal X3)	6 CAN bus connection

4.5.5.2 PIO card

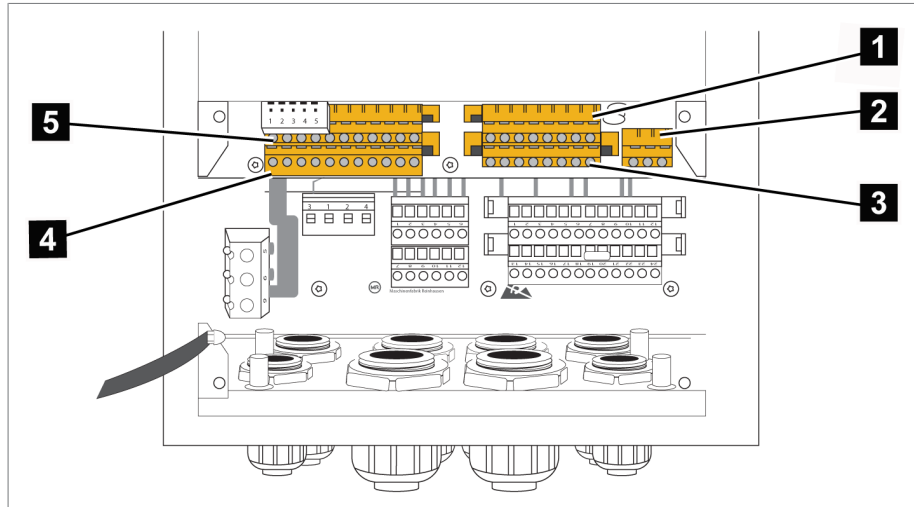

Figure 13: PIO card

- | | |
|--|-------------------------------|
| 1 Signal inputs and auxiliary voltage generation (terminal X6) | 4 Relay outputs (terminal X5) |
| 2 Analog input (terminal X7) | 5 Relay outputs (terminal X5) |
| 3 Digital tap position inputs (terminal X6) | |

5 Packaging, transport and storage

5.1 Packaging

5.1.1 Purpose

The packaging is designed to protect the packaged goods during transport, loading and unloading as well as periods of storage in such a way that no (detrimental) changes occur. The packaging must protect the goods against permitted transport stresses such as vibration, knocks and moisture (rain, snow, condensation).

The packaging also prevents the packaged goods from moving impermissibly within the packaging. The packaged goods must be prepared for shipment before actually being packed so that the goods can be transported safely, economically and in accordance with regulations.

5.1.2 Suitability, structure and production

The goods are packaged in a sturdy cardboard box. This ensures that the shipment is secure when in the intended transportation position and that none of its parts touch the loading surface of the means of transport or touch the ground after unloading.

The box is designed for a maximum load of 10 kg.

Inlays inside the box stabilize the goods, preventing impermissible changes of position, and protect them from vibration.

5.1.3 Markings

The packaging bears a signature with instructions for safe transport and correct storage. The following symbols apply to the shipment of non-hazardous goods. Adherence to these symbols is mandatory.





				
Protect against moisture	Top	Fragile	Attach lifting gear here	Center of mass

Table 6: Shipping pictograms

5.2 Transportation, receipt and handling of shipments

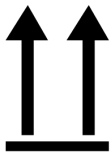
In addition to oscillation stress, jolts must also be expected during transportation. In order to prevent possible damage, avoid dropping, tipping, knocking over and colliding with the product.



If a crate tips over, falls from a certain height (e.g. when slings tear) or is subject to an unbroken fall, damage must be expected regardless of the weight.

Every delivered shipment must be checked for the following by the recipient before acceptance (acknowledgment of receipt):

- Completeness based on the delivery slip
- External damage of any type

The checks must take place after unloading when the crate or transport container can be accessed from all sides.

Visible damage If external transport damage is detected on receipt of the shipment, proceed as follows:

- Immediately record the transport damage found in the shipping documents and have this countersigned by the carrier.
- In the event of severe damage, total loss or high damage costs, immediately notify the sales department at Maschinenfabrik Reinhausen and the relevant insurance company.
- After identifying damage, do not modify the condition of the shipment further and retain the packaging material until an inspection decision has been made by the transport company or the insurance company.
- Record the details of the damage immediately onsite together with the carrier involved. This is essential for any claim for damages!
- If possible, photograph damage to packaging and packaged goods. This also applies to signs of corrosion on the packaged goods due to moisture inside the packaging (rain, snow, condensation).
- Be absolutely sure to also check the sealed packaging.

Hidden damage When damages are not determined until unpacking after receipt of the shipment (hidden damage), proceed as follows:

- Make the party responsible for the damage liable as soon as possible by telephone and in writing, and prepare a damage report.
- Observe the time periods applicable to such actions in the respective country. Inquire about these in good time.

With hidden damage, it is very hard to make the transportation company (or other responsible party) liable. Any insurance claims for such damages can only be successful if relevant provisions are expressly included in the insurance terms and conditions.



5.3 Storage of shipments

When selecting and setting up the storage location, ensure the following:

- Protect stored goods against moisture (flooding, water from melting snow and ice), dirt, pests such as rats, mice, termites and so on, and against unauthorized access.
- Store the crates on timber beams and planks as a protection against rising damp and for better ventilation.
- Ensure sufficient carrying capacity of the ground.
- Keep entrance paths free.
- Check stored goods at regular intervals. Also take appropriate action after storms, heavy rain or snow and so on.

6 Mounting

This chapter describes how to correctly install and connect the device. Observe the connection diagrams provided.

▲ DANGER



Electric shock!

Risk of fatal injury due to electrical voltage. Always observe the following safety regulations when working in or on electrical equipment.

- ▶ Disconnect the equipment.
- ▶ Lock the equipment to prevent an unintentional restart.
- ▶ Make sure all poles are de-energized.
- ▶ Ground and short-circuit.
- ▶ Cover or cordon off adjacent energized parts.

▲ WARNING



Electric shock!

Dangerous high voltages may occur when a current transformer is operated with an open secondary circuit. This can lead to death, injuries and property damage.

- ▶ Never operate a current transformer with an open secondary circuit; short-circuit the current transformer to prevent this.
- ▶ Observe the information in the current transformer operating instructions.

NOTICE

Damage to the device!

Electrostatic discharge may cause damage to the device.

- ▶ Take precautionary measures to prevent the build-up of electrostatic charges on work surfaces and personnel.

6.1 Preparation

The following tools are needed for mounting:

- Provided 3mm Allen key (included in delivery)
- Small screwdriver for connecting the signal lines and supply lines



Other tools may be needed depending on installation location.

6.2 Mounting device

You can mount the device in the following installation versions:

- Flush panel mounting
- Wall mounting

- Wall mounting with mounting brackets
- Rail mounting (optional)

Preparing for mounting

Before commencing mounting, the two mounting brackets back on the rear of the device must be removed and the cable gland plate taken off. To do so, proceed as follows:

1. Loosen the 4 Allen screws with attached Allen key to remove the mounting brackets.

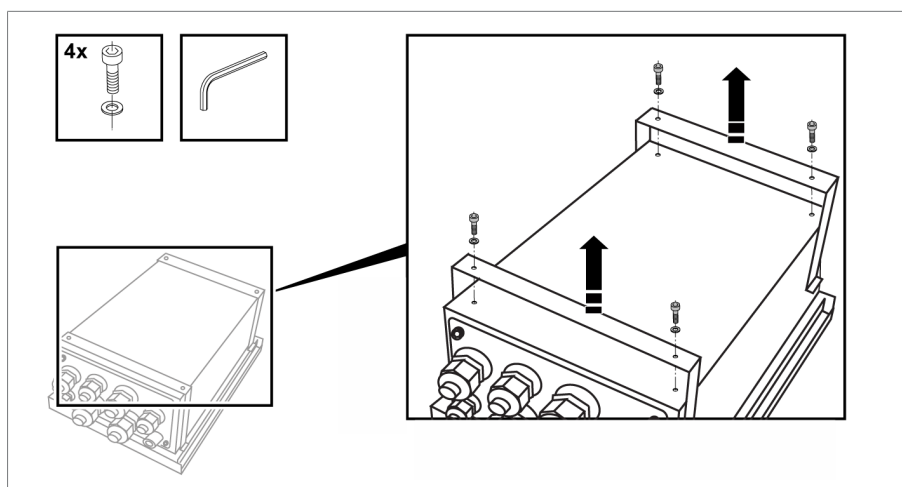

Figure 14: Loosen mounting bracket

2. Loosen the 4 Allen screws with attached Allen key to remove the cable gland plate.

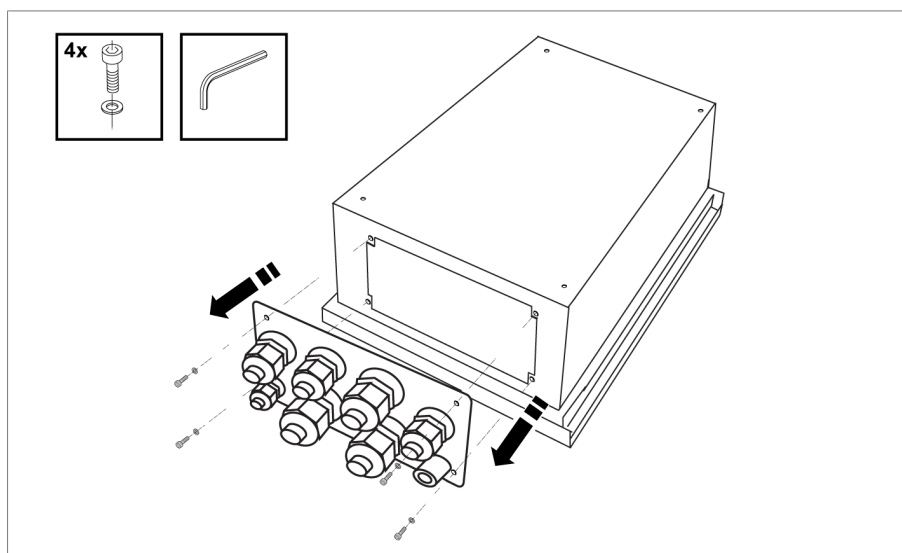

Figure 15: Loosen cable gland plate

⇒ The mounting brackets and the cable gland plate are removed.

The relevant installation versions are described in the following sections.

6.2.1 Flush panel mounting

For flush panel mounting, the device is inserted through a cutout in the control panel and fixed to the control panel or control cabinet from behind using the mounting brackets. The diagram below shows the dimensions required for the control panel cutout.

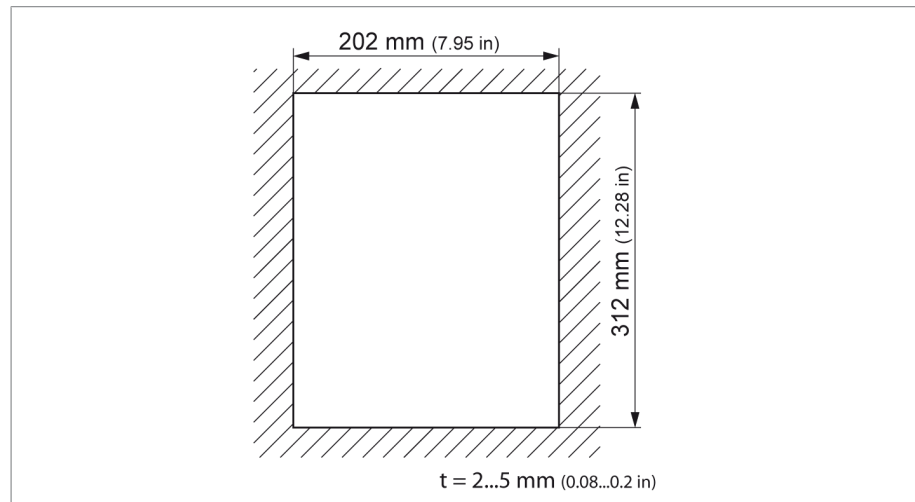

Figure 16: Dimensions for the cutout



A wall thickness of 2...5 mm (0.08...0.2 in) is needed for secure device fixing.

To mount the device in the control panel or control cabinet, proceed as follows:

1. Close the device's door.
2. Insert the device through the cutout in the control panel or control cabinet **1**.

3. Screw both fixing brackets to the rear of the device with 2 hexagon socket screws each **2**.

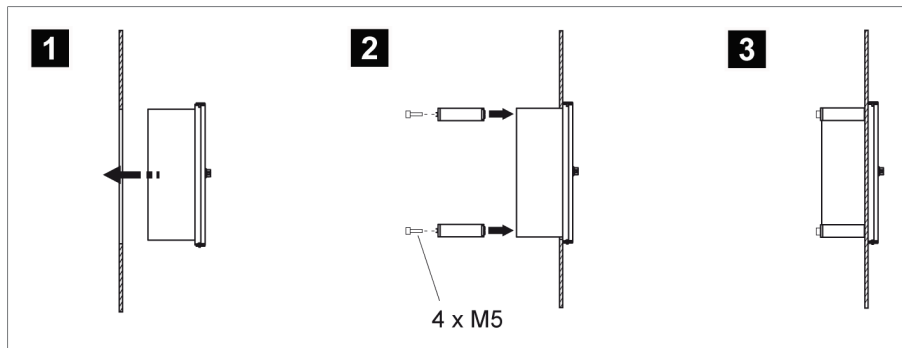

Figure 17: Flush panel mounting

⇒ The device is mounted and can be wired up **3**.

Proceed with wiring as shown in the connection diagram and as described in the Connecting device [► Section 6.3, Page 37] section.

6.2.2 Wall mounting with mounting brackets

As an alternative to mounting the device directly on the wall, it can be fixed to the wall using the mounting brackets supplied.

Drill 4 holes, each 5.5 mm (0.22 in) in diameter, in the wall as shown in the drilling template below.

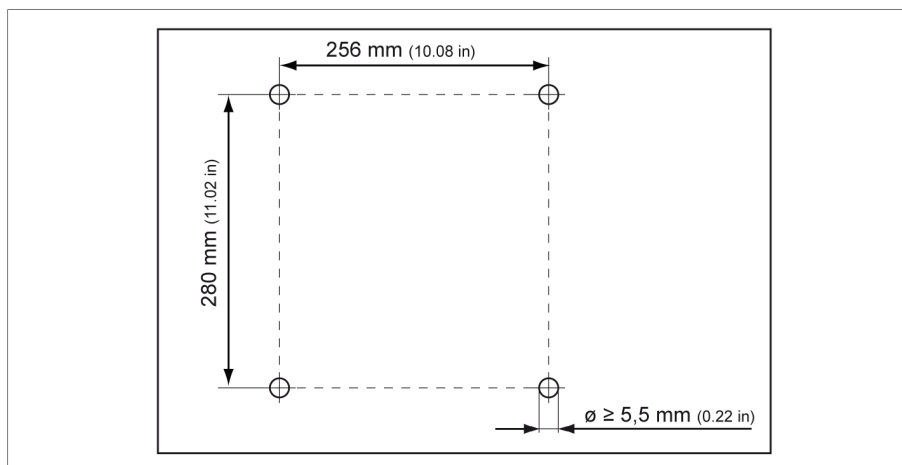

Figure 18: Bores for wall mounting with mounting brackets

To mount the device using the mounting brackets, proceed as follows:

1. Lay the device carefully on the door.
2. Screw the mounting brackets supplied to the back of the device using the hexagon socket screws **1**.

3. Fix the device on the wall using 4 screws (maximum diameter of 5 mm/0.22 in) **2**.



The screws for fixing to the wall are not included in the scope of supply. The screw length required depends on the wall thickness.

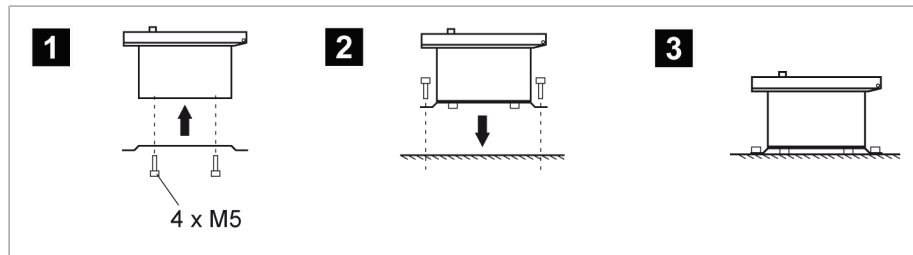

Figure 19: Wall mounting with mounting brackets

⇒ The device is mounted and can be wired up **3**.

Proceed with wiring as shown in the connection diagram and as described in the Connecting device [► Section 6.3, Page 37] section.

6.2.3 Cap rail mounting

As an option, the device can be fitted with a cap rail clip (aluminum extrusion with wire spring integrated at center). This enables you to mount the device on a cap rail.



When attaching the cap rail, sufficient space for the device must be planned for. At least 5 cm (1.97 in) of space must be provided above and at least 35 cm (13.78 in) below the fixing screws of the cap rail for the device housing.

To mount the device using the cap rail, proceed as follows:

1. Lay the device carefully on the door.
2. Screw the cap rail clip into the two top holes on the rear with the M5 hexagon socket countersunk head screws provided **1**.



3. Suspend the cap rail clip in the cap rail and push the underside carefully towards the wall until the clip can be heard to click into place **2**.

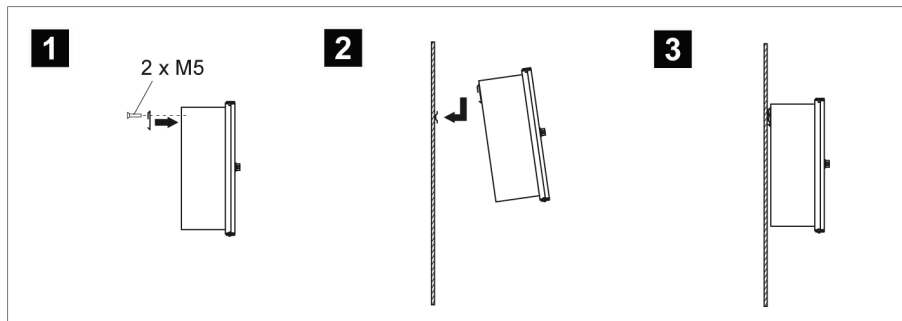

Figure 20: Cap rail mounting

⇒ The device is mounted and can be wired up **3**.

Proceed with wiring as shown in the connection diagram and as described in the Connecting device [▶ Section 6.3, Page 37] section.

6.2.4 Wall mounting

For wall mounting, the device is fixed directly to the wall. Drill 4 holes, each 5.5 mm in diameter, in the wall as shown in the drilling template below.

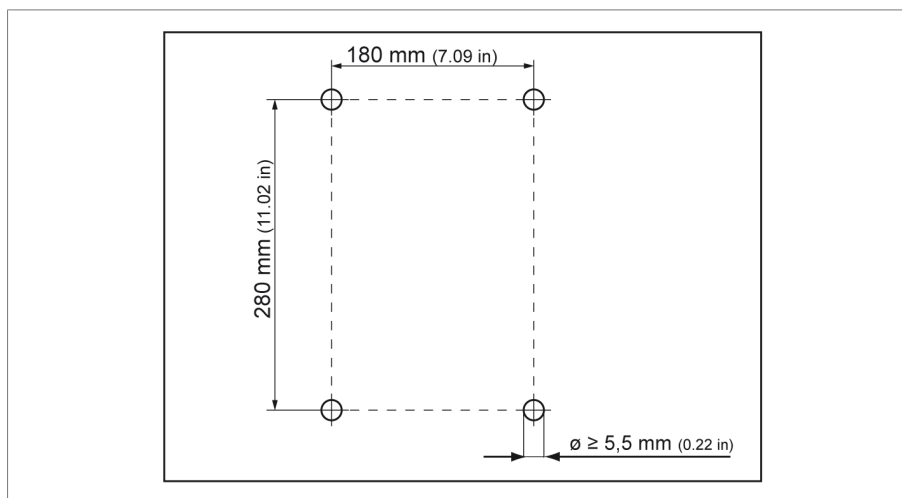

Figure 21: Drilling template for wall mounting

To mount the device directly on the wall, proceed as follows:

- ✓ Close the device's door.
- ▶ Fix the device on the wall from behind using 4 screws (M5) **2**.



The screws for wall mounting are not included in the scope of supply. The screw length required depends on the wall thickness.

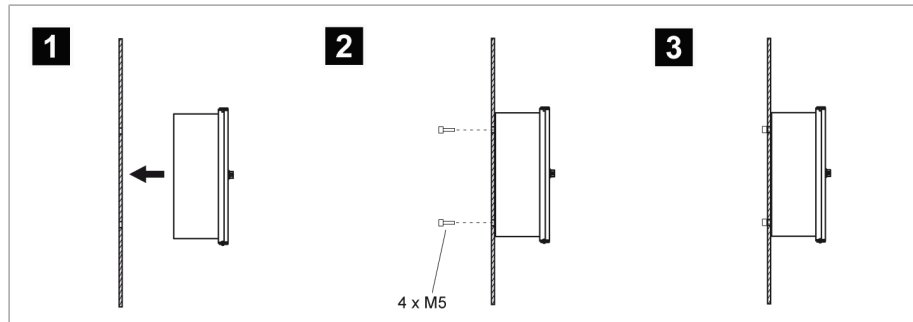

Figure 22: Wall mounting

⇒ The device is mounted and can be wired up **3**.

Proceed with wiring as shown in the connection diagram and as described in the Connecting device section.

6.2.5 Removing the door

When the door is fitted, the device satisfies protection category IP54. The door may be removed if the device is used solely in a dry atmosphere protected from environmental influences. The device then satisfies protection category IP21.

Proceed as follows to remove the door:

1. Loosen the grounding strap on the door using an open-end wrench.

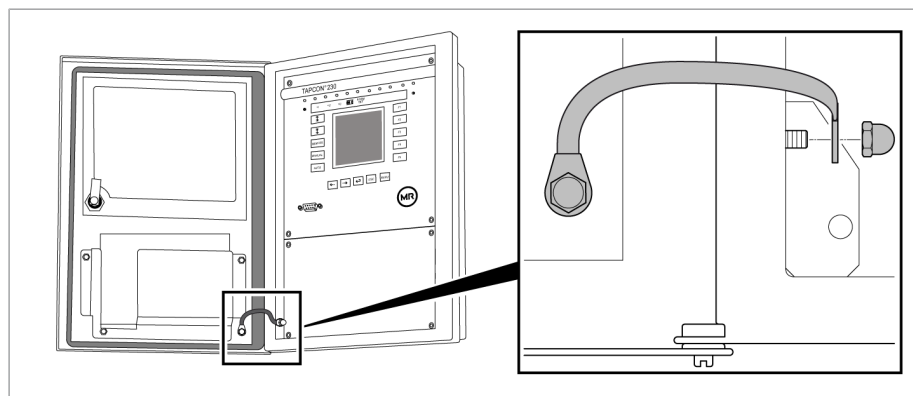

Figure 23: Remove door

2. Unscrew the fixing bolt using a slotted screwdriver and **1** lift the door out of the upper mounting **2**.

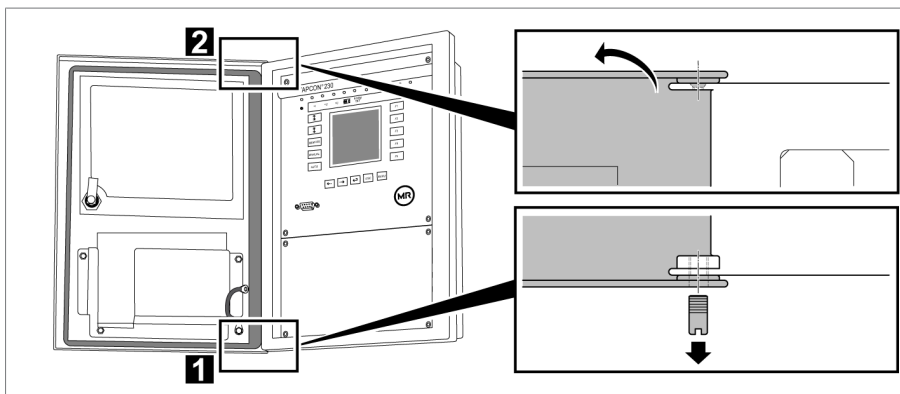

Figure 24: Lift door from the suspension mount

3. Hook the cover strip in the upper **1** and lower **2** suspension mount and fasten it with the provided raised countersunk head screws.

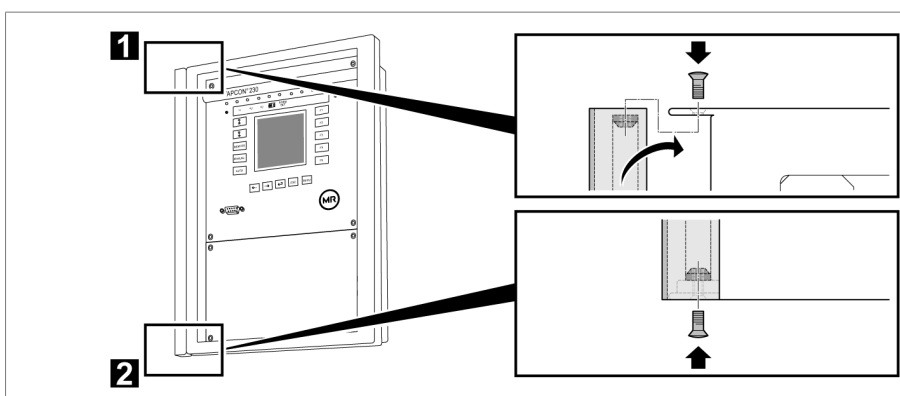

Figure 25: Fasten covering strip

⇒ The door is removed and the exposed attachment points for the door are covered.

6.3 Connecting device

The following section describes how to establish the electrical connection to the device.

▲ WARNING



Electric shock!

Connection errors can lead to death, injury or property damage.

- ▶ Ground the device with a protective conductor using the grounding screw on the housing.
- ▶ Note the phase difference of the secondary terminals for the current transformer and voltage transformer.
- ▶ Connect the output relays correctly to the motor-drive unit.



Supply the voltage via separators and ensure that current paths can be short circuited. Fit the separator, clearly labeled, close to the device's power supply so that it is freely accessible. This ensures that the device can be replaced with ease in the event of a defect.

Wiring information

Note this procedure for the wiring:

- ✓ To obtain a better overview when connecting cables, only use as many leads as necessary.
 - ✓ Note the connection diagram.
 - ✓ Use only the specified cables for wiring. Note the cable recommendation [► Section 6.3.1, Page 38].
 - ✓ Wire the leads to the system periphery [► Section 6.3.4, Page 44].
1. Strip insulation from leads and wires.
 2. Crimp stranded wires with wire end sleeves.

6.3.1 Cable recommendation

Please note the following recommendation from Maschinenfabrik Reinhausen when wiring the device.



Excessive line capacitance can prevent the relay contacts from breaking the contact current. In control circuits operated with alternating current, take into account the effect of the line capacitance of long control cables on the function of the relay contacts.

Cable	Terminal	Cable type	Wire cross-section	Max. length	Max. permissible torque
Analog input	X7	Shielded (< 25 Ω/km)	1.5 mm ²	400 m	-
Signal inputs	X4	Shielded	1.5 mm ²	-	0.6 Nm
RS232 SUB-D	-	Shielded	0.25 mm ²	25 m	-
RS485	-	Shielded (< 50 Ω/km)	0.75 mm ²	1000 m	-
Ethernet RJ45	-	min. CAT5	-	-	-
Relay outputs*	X3	Unshielded	1.5 mm ²	-	0.6 Nm
Relay outputs* optional	X4	Unshielded	1.5 mm ²	-	0.6 Nm
Current measurement	X1:5/6/9	Unshielded	4 mm ²	-	1.5 Nm
Voltage measurement	X2:1/2	Shielded	1.5 mm ²	-	0.6 Nm
Relay outputs	X5	Unshielded	1.5 mm ²	-	0.6 Nm
Signal inputs	X6	Unshielded	1.5 mm ²	-	0.6 Nm

Cable	Terminal	Cable type	Wire cross-section	Max. length	Max. permissible torque
Digital tap position inputs	X6	Shielded	1.5 mm ²	-	0.6 Nm
Auxiliary voltage	X6	Unshielded	1.5 mm ²	-	0.6 Nm
Power supply	X2:3/4	Unshielded	1.5 mm ²	-	0.6 Nm
CAN bus	-	Shielded	1.0 mm ²	2000 m	-

Table 7: Cable recommendation for connection cable

*) Observe line capacitance, see note above.



Cable clips X1 to X4 are on the MIO card of the device. Cable clips X5 to X7 are on the PIO card of the device.

6.3.2 Information about laying fiber-optic cable

To ensure the smooth transfer of data via the fiber-optic cable, you must ensure that mechanical loads are avoided when laying the fiber-optic cable and later on during operation. Also observe the information from the manufacturer of the fiber-optic cable and the following instructions:

- Radii must not fall below the minimum permissible bend radii (do not bend fiber-optic cable).
- The fiber-optic cables must not be over-stretched or crushed. Observe the permissible load values.
- The fiber-optic cables must not be twisted.
- Be aware of sharp edges because they can damage the fiber-optic cable's coating during laying or can place mechanical loads on the coating later on.
- Provide a sufficient cable reserve near distributor cabinets. Lay the reserve such that the fiber-optic cable is neither bent nor twisted when tightened.

6.3.3 Electromagnetic compatibility

The device has been developed in accordance with applicable EMC standards. The following points must be noted in order to maintain the EMC standards.

6.3.3.1 Wiring requirement of installation site

Note the following when selecting the installation site:

- The system's overvoltage protection must be effective.
- The system's ground connection must comply with all technical regulations.

- Separate system parts must be joined by a potential equalization.
- The device and its wiring must be at least 10 m away from circuit-breakers, load disconnectors and busbars.

6.3.3.2 Wiring requirement of operating site

Note the following when wiring the operating site:

- Route the connecting leads in grounded metal cable ducts.
- Do not route lines which cause interference (e.g. power lines) and lines susceptible to interference (e.g. signal lines) in the same cable duct.
- Maintain a distance of more than 100 mm between lines which cause interference and those which are susceptible to interference.

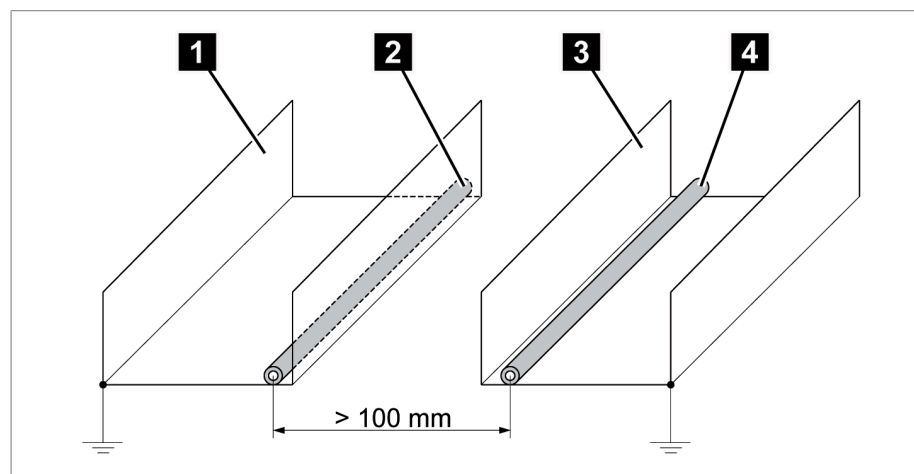

Figure 26: Recommended wiring

1 Cable duct for lines causing interference	3 Cable duct for lines susceptible to interference
2 Line causing interference (e.g. power line)	4 Line susceptible to interference (e.g. signal line)

- Short-circuit and ground reserve lines.
- Never connect the device with a multi-wire collective pipe.
- For signal transmission, use shielded lines with individual conductors (outgoing conductor / return conductor) twisted in pairs.
- Connect full surface of shielding (360°) to device or to a nearby grounding bar.



Using single conductors may limit the effectiveness of the shielding. Connect close-fitting shielding to cover all areas.

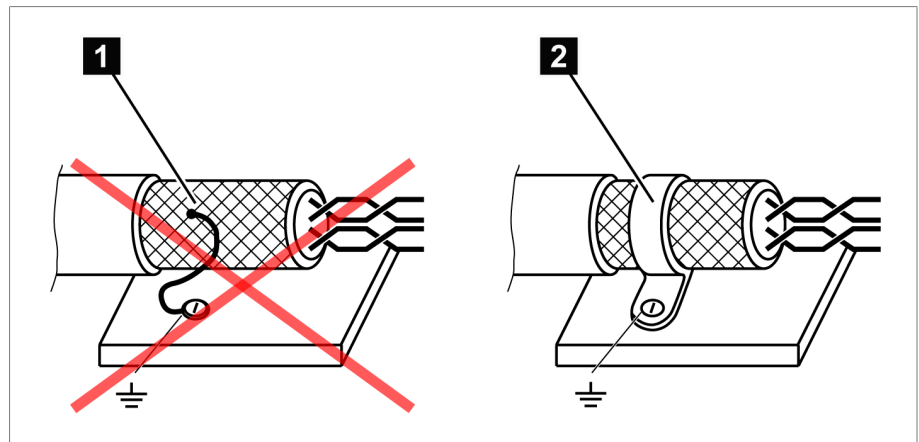

Figure 27: Recommended connection of the shielding

1 Connection of the shielding via a single conductor

2 Full-surface connection of the shielding

6.3.3.3 Wiring requirement in control cabinet

Note the following when wiring the control cabinet:

- The control cabinet where the device will be installed must be prepared in accordance with EMC requirements:
 - Functional division of control cabinet (physical separation)
 - Constant potential equalization (all metal parts are joined)
 - Line routing in accordance with EMC requirements (separation of lines which cause interference and those susceptible to interference)
 - Optimum shielding (metal housing)
 - Overvoltage protection (lightning protection)
 - Collective grounding (main grounding rail)
 - Cable bushings in accordance with EMC requirements
 - Any contactor coils present must be interconnected
- The device's connection cables must be laid in close contact with the grounded metal housing or in metallic cable ducts with a ground connection.
- Signal lines and power lines/switching lines must be laid in separate cable ducts.
- The device must be grounded at the screw provided, the protective grounding connection, using a ground strap (cross-section min. 8 mm²).

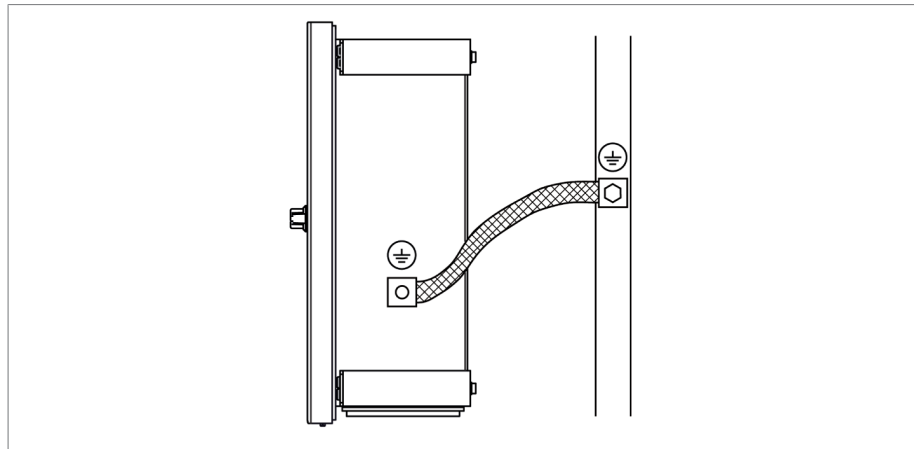

Figure 28: Ground strap connection

Ground connection for wiring inside the device

The diagram below shows the ground connection for wiring inside the device.

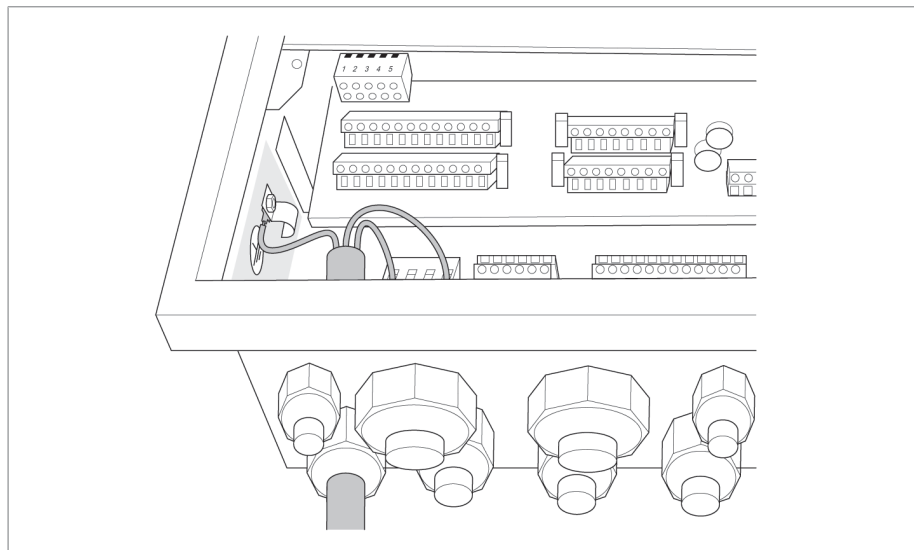

Figure 29: Grounding inside the device

6.3.3.4 Information about shielding the CAN bus

In order for the CAN bus to operate faultlessly, you have to connect the shielding using one of the following variants. If you are not able to use any of the variants detailed below, we recommend using fiber-optic cables. Fiber-optic cables decouple the devices and are not sensitive to electromagnetic interference (surge and burst).

NOTICE
Damage to the device!

If you connect the CAN bus cable to devices with different potentials, current may flow across the shielding. This current may damage the device.

- ▶ Connect the devices to a potential equalization rail to equalize the potential.
- ▶ If both devices have different potentials, only connect the CAN bus cable shielding to one device.

Variant 1: The connected devices share the same potential

If the devices to be connected share the same potential, proceed as follows:

1. Connect all devices to a potential equalization rail to equalize the potential.
2. Connect the CAN bus cable shielding to all connected devices.

Variant 2: The connected devices have different potentials

Note that the shielding is less effective with this variant.



If the devices to be connected have different potentials, proceed as follows:

- ▶ Connect the CAN bus cable shielding to **just one** device.

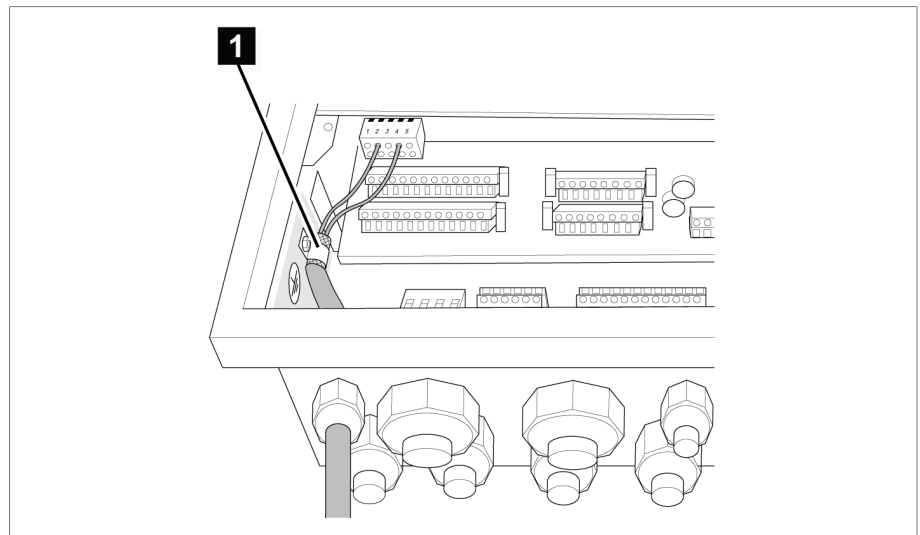

Figure 30: Securing the shielding

1 Securing the CAN bus cable's shielding

6.3.4 Connecting cables to the system periphery



To obtain a better overview when connecting cables, only use as many leads as necessary.

To connect cables to the system periphery, proceed as follows:

- ✓ Use only the specified cables for wiring. Note the cable recommendation.
- ▶ Connect the lines to be wired to the device to the system periphery as shown in the connection diagrams supplied.

6.3.5 Supplying the voltage regulator using auxiliary voltage

The device is normally supplied by the voltage transformer. If the voltage transformer does not provide the supply voltage and power (see "Technical Data") needed for operation, the device must be supplied via a 88...265V AC/DC, 50...60Hz auxiliary supply .

Proceed as follows to supply the device with auxiliary voltage:

1. **NOTICE!** Voltage transformer damage Connecting an auxiliary voltage when bridges are present between the X2:1/3 and X2:2/4 terminals can result in voltage transformer damage. Remove the bridges between the terminals X2:1/3 and X2:2/4.
2. Connect the voltage transformer to terminals X2:1 and X2:2.
3. Connect the auxiliary voltage using the following terminals: X2:3 and X2:4.

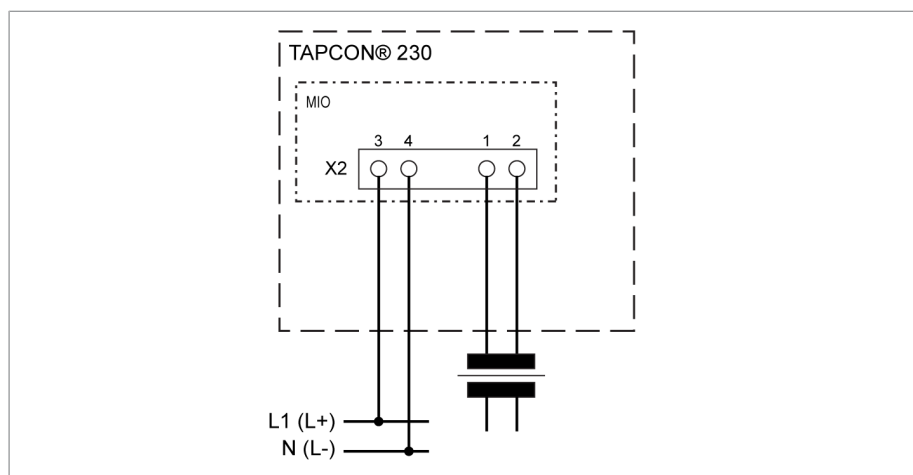

Figure 31: Voltage transformer and auxiliary supply connections

6.3.6 Wiring device



To obtain a better overview when connecting cables, only use as many leads as necessary.



To wire the device, proceed as follows:

- ✓ Use only the specified cables for wiring. Note the cable recommendation [► Section 6.3.1, Page 38].
 - ✓ Wire the lines to the system periphery [► Section 6.3.4, Page 44].
1. Remove 4 hexagon socket screws from cover plate and take off cover plate.
 2. Disconnect the connectors required.
 3. Remove 4 hexagon socket screws from the cable gland plate and take off the cable gland plate.
 4. Remove dummy plug from required cable glands in order to guide cables through.



Unnecessary cable glands must be sealed with dummy plugs to guarantee the IP54 protection category.

5. Strip insulation from lines and leads.
6. Crimp stranded wires with core cable ends.
7. Guide cables through the cable gland
8. Guide leads into corresponding connector terminals.
9. Fasten screws for the corresponding terminals using a screwdriver.
10. Guide the cable gland plate into the device opening provided for this purpose.
11. Plug connectors into the correct slots.
12. Secure cable gland plate to device housing with 4 hexagon socket screws.

6.3.7 Checking functional reliability

To ensure that the device is wired correctly, check its functional reliability.

NOTICE

Damage to device and system periphery

An incorrectly connected device can lead to damages in the device and system periphery.

- Check the entire configuration before commissioning.
- Prior to commissioning, be sure to check the actual voltage and operating voltage.

Check the following:

- Once you have connected the device to the grid, the screen displays the MR logo and then the operating screen.
- The green *Operating display* LED top left on the device's front panel lights up.



The device is fully mounted and can be configured. The actions required for this are described in the following chapter.



7 Commissioning

You need to set several parameters and perform function tests before commissioning the device. These are described in the following sections.

NOTICE

Damage to device and system periphery

An incorrectly connected device can lead to damages in the device and system periphery.

- ▶ Check the entire configuration before commissioning.
- ▶ Prior to commissioning, be sure to check the actual voltage and operating voltage.



We recommend using a device for industrial instrumentation to record the actual transformer voltage value in order to evaluate how the device is functioning.

7.1 Setting the display contrast

You can adjust the contrast in the display with the help of an adjustment screw on the front of the device. To adjust the contrast, proceed as follows:

- ▶ Use a screwdriver to turn the adjustment screw on the front until the contrast is adjusted to the desired setting.

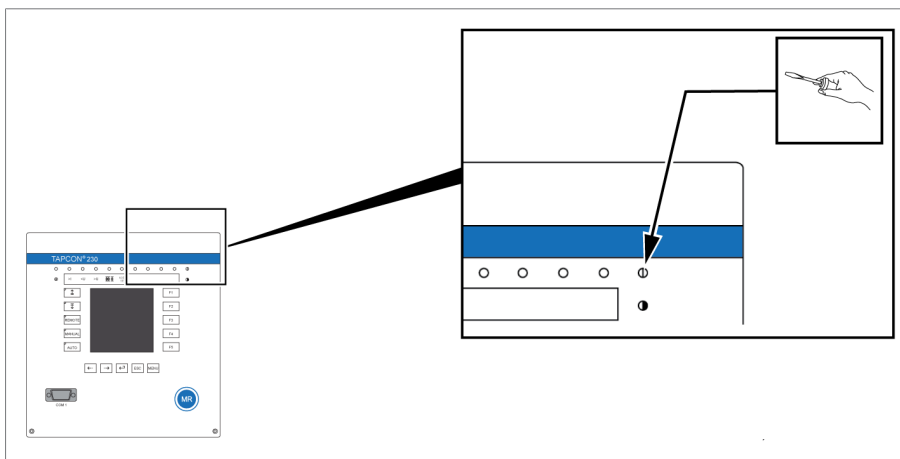

Figure 32: Setting the display contrast

7.2 Setting parameters

To commission the device, you must set the following parameters. For more detailed information about the parameters, refer to the respective sections.

7.2.1 Setting the language

You can use this parameter to set the display language for the device. The following languages are available:

English	Italian
German	Portuguese
French	Russian
Spanish	

To set the language, proceed as follows:



1. **MENU** > **F4** Configuration > **F3** General.
⇒ Language
2. Press **F1** or **F5** to select the required language.
3. Press **←**.
⇒ The language is set.

7.2.2 Setting further parameters

Set further parameters to commission the device. You will find more detailed information about the respective parameters in the "Operation" [► Section 8, Page 60] chapter.

Setting transformer data

Set the transformer data and phase difference of the current transformer and voltage transformer:

1. Set primary transformer voltage [► Section 8.7.1, Page 95].
2. Set secondary transformer voltage [► Section 8.7.2, Page 95].
3. Set primary transformer current [► Section 8.7.3, Page 96].
4. Select current-transformer connection [► Section 8.7.4, Page 96].
5. Select transformer circuit [► Section 8.7.5, Page 97].

Setting NORMset

If you want to commission voltage regulation quickly, you can activate NORMset mode. If you want to set the parameters yourself, continue with the sections below.

- Activate NORMset and set the relevant parameters [► Section 8.3, Page 70].

Setting control parameters

Set the following control parameters:

1. Set desired value 1 [► Section 8.4.1, Page 74].



2. Set the bandwidth [► Section 8.4.3.2, Page 77].
3. Set delay time T1 [► Section 8.4.4, Page 77].

Setting line drop compensation (optional)

If you need line drop compensation, you must set all important parameters for this:

1. Select the LDC compensation method [► Section 8.6.1, Page 89].
2. Set the line data for the ohmic voltage drop U_r [► Section 8.6.1.1, Page 91].
3. Set the line data for the inductive voltage drop U_x [► Section 8.6.1.2, Page 91].

Setting parallel operation (optional)

If you need parallel operation, you must set all important parameters for this:

1. Set parallel operation method to circulating reactive current method [► Section 8.8.2.1, Page 102].
2. Assign CAN bus address [► Section 8.8.1, Page 102].
3. Set circulating reactive current sensitivity [► Section , Page 103].
4. Set circulating reactive current blocking [► Section , Page 103].

Setting tap position capture via analog input (optional)

If you want to capture the tap position via the analog input, you must set the parameters required for this:

- Capture tap positions via analog input (PIO card terminal strip X7) [► Section 8.9.2, Page 110].

All parameters relevant to commissioning are entered. Continue with the function tests.

Setting the desired voltage level remotely

If you would like to set the desired voltage level remotely, you must configure the necessary parameters:

- Activate "Set the desired voltage level remotely" and set the relevant parameters [► Section 8.10, Page 113].

7.3 Calibrating the analog input

Before you can use the analog input, you need to calibrate it. Calibration is used to adjust the external measuring circuit.



The **F3** key can be used to cancel the calibration at any point.

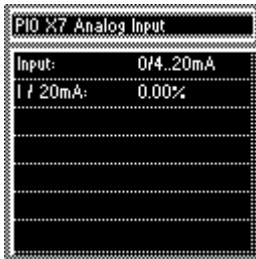

To carry out the calibration, proceed as follows:

1. **MENU** > **F5** Info > Press **→** until the desired measurement parameter is displayed.
⇒ PIO X7 analog input
2. Press **F5** to start the calibration.
⇒ A screen containing instructions is displayed.
3. Connect resistor contact series (potentiometer series).
4. Turn resistor contact series into end position "Rmax".
5. Press **F5** to carry out the calibration.

The procedure may take up to 3 minutes. If this time is exceeded, the "Check sliding contact" error message is displayed. In this case, make sure that the resistor contact series is correctly connected and is not faulty.

To configure further parameters for setting the tap position capture remotely, proceed as follows:

1. Select analog tap position capture [► Section 8.10, Page 113].
 2. Set lower limit value [► Section 8.10.2, Page 114]
 3. Set upper limit value [► Section 8.10.3, Page 115]
- ⇒ The analog tap position capture is set.

7.4 Function tests

Before switching from manual mode to auto mode, Maschinenfabrik Reinhausen recommends carrying out function tests. These function tests are described in the following sections. Note the following points for all function tests:













- You must ensure that REMOTE mode is disabled before you can control the on-load tap-changer manually in manual mode.
- You can only activate the on-load tap-changer manually in manual mode using the **↑** and **↓** keys.
- During the function test, you must set the most important parameters. Details on the parameters listed can be found in the Operation [► Section 8, Page 60] chapter.



7.4.1 Checking control functions

This section describes how you can check the device's control functions:

✓ Supply voltage must be present.

1. Press  to select manual mode.
2. Set transmission ratio for voltage transformer, current transformer and measuring set-up.
3. Measure actual voltage and compare with the measured value displayed on the device's main screen.
4. Press  key several times to display the operating values for current, power and phase angle and compare them with values of service instruments.
5. Control the on-load tap-changer manually with the  or  keys until the measured voltage (U_{actual}) reaches the desired voltage (U_{desired}) set in the next stage.
6. Set desired value 1 to the value you want.
7. Set bandwidth depending on step voltage [► Section 8.4.3, Page 76].
8. Set delay time T1 to 20 seconds [► Section 8.4.4, Page 77].
9. Set control response T1 to linear [► Section 8.4.5, Page 78].
10. Press  to raise the on-load tap-changer 1 step.
11. Press  to select auto mode.
 - ⇒ After 20 seconds, the device returns the on-load tap-changer to the original operating position.
12. Press  to select manual mode.
13. Press  to lower the on-load tap-changer 1 step.
14. Press  to select auto mode.
 - ⇒ After 20 seconds, the device returns the on-load tap-changer to the original operating position.
15. Press  to select manual mode.
16. Set delay time T2 to 10 seconds [► Section , Page 79].
17. Activate delay time T2.
18. Press  twice to raise the on-load tap-changer 2 steps.
19. Press  to select auto mode.
 - ⇒ After 20 seconds, the device lowers the on-load tap-changer one step and after another 10 seconds another step.
20. Press  to select manual mode.
21. Set delay time T1 [► Section 8.4.4, Page 77] and delay time T2 [► Section , Page 79] to the desired value.



We recommend a temporary setting of 100 seconds for **delay time T1** when commissioning the transformer. Depending on the operating conditions, you can also specify the delay time following a longer observation period. In this regard, it is useful to register how the actual voltage progresses and the number of tap-change operations per day.

7.4.2 Checking additional functions

This section describes how you can check the following additional functions:

- Undervoltage blocking
- Overvoltage blocking
- Activation of desired values 2 and 3
- Line drop compensation
- Z compensation

Proceed as follows:

Checking undervoltage blocking U<

1. Press to select manual mode.
2. Set undervoltage U < [%] to 85 %.
3. Set the U< blocking parameter to On [► Section , Page 82].
4. Set desired value 1 such that the measured voltage U_{actual} is below the undervoltage U< [%] limit value.



Measured voltage = 100 V

Desired value 1 = Set to 120 V (greater than $100 \text{ V} / 0.85 = 117 \text{ V}$).

- ⇒ The *Undervoltage U<* LED will light up.
 - ⇒ After around 10 seconds the *Undervoltage* message appears in the display and the relevant signaling relay is activated. Contact X4:1/3 closes and contact X4:2/3 opens.
5. Press to select auto mode.
 - ⇒ The device blocks and does not issue any control commands.
 6. Press to select manual mode.
 7. Reset the operating values for **desired value 1** and **undervoltage U< [%]** to the desired operating values.
 - ⇒ The function test for undervoltage blocking is complete.

Checking overvoltage blocking U>

1. Press to select manual mode.
2. Set overvoltage U> [%] to 115 %.
3. Set the absolute limit values parameter to Off.



- Set desired value 1 such that the measured voltage U_{actual} is above the overvoltage $U > [\%]$ limit value.

Measured voltage = 100 V

Desired value 1 = Set to 85 V (less than $100 \text{ V} / 1.15 = 87 \text{ V}$).

- ⇒ The *Overvoltage* $U >$ LED will light up.
 - ⇒ The *Overvoltage* message appears in the display and the relevant signaling relay is activated. Contact $X4:1/3$ closes and contact $X4:2/3$ opens.
- Press to select auto mode.
 - ⇒ The LOWER output relay emits a control command every 1.5 seconds.
 - Press to select manual mode.
 - Reset the operating values for **desired value 1** and **overvoltage $U > [\%]$** to the desired operating values.
 - ⇒ The function test for overvoltage blocking is complete.





Checking desired value 2 and desired value 3

- Press to select manual mode.
 - Set **desired value 2** to the value you want.
 - Apply voltage $L+$ to terminal $X4:17$ *desired value 2* (see connection diagram).
 - Press until the main screen is displayed.
 - ⇒ **Desired value 2** is shown on the main screen.
 - Set desired value 3 to the value you want.
 - Apply voltage $L+$ to terminal *desired value 3* (see connection diagram).
 - Press until the main screen is displayed.
 - ⇒ **Desired value 3** is shown on the main screen.
- ⇒ The function test for **desired value 2** and **desired value 3** is complete.

Checking line drop compensation

If you want to use line drop compensation, you need to run this function test. A load current of $\geq 10 \%$ of the nominal transformer current is needed for the following function tests. Before the function test, ensure that all parameters for line drop compensation and for Z compensation are set to **0**.

- Press to select manual mode.
- Set the compensation method parameter to LDC.
- Press until the main screen is displayed.

4. If necessary, press  until the control deviation **dU** is shown.
⇒ The measured voltage must be within the bandwidth.
5. Set line drop compensation **Ur** parameter to 20.0 V.
6. Press  until the main screen is displayed.
7. If necessary, press  until the control deviation **dU** is shown.
⇒ The value for control deviation **dU** must be negative.
8. Set line drop compensation **Ur** parameter to -20.0 V.
9. Press  until the main screen is displayed.
10. If necessary, press  until the control deviation **dU** is shown.
⇒ The value for control deviation **dU** must be positive.







If the control deviation appears in the opposite direction, change the polarity of the current transformer.

11. Set the **line drop compensation Ur** and **line drop compensation Ux** parameters to the desired operating values.
⇒ The function test for line drop compensation is complete.

Checking Z compensation

If you want to use Z compensation, you need to run this function test. A load current of $\geq 10\%$ of the nominal transformer current is needed for the following function test .

1. Press  to select manual mode.
2. Set all parameters for line drop compensation and Z compensation to 0.
3. Set the compensation method parameter to Z.
4. Press  until the main screen is displayed.
5. If necessary, press  until the control deviation **dU** is shown.
⇒ The measured voltage must be within the bandwidth.
6. Set the Z compensation parameter to 15.0 V.
7. Press  until the main screen is displayed.
8. If necessary, press  until the control deviation **dU** is shown.
⇒ The control deviation **dU** must be negative.



If the control deviation appears in the opposite direction, change the polarity of the current transformer.



9. Set the **Z compensation** and **Z compensation limit value** parameters to the desired operating values.

⇒ The function test for Z compensation is complete.

7.4.3 Checking parallel operation

This section describes how you can run the function test for parallel operation.

Requirements To obtain perfect functioning in parallel operation, the voltage regulator must be commissioned in simplex mode. Make sure that the conditions below have been fulfilled.

- All devices are set to the same operating parameters for **desired value**, **circulating reactive current sensitivity** and **delay time T1**.
- The circulating reactive current sensitivity on all devices must be set to 0 %.
- The **circulating reactive current blocking** parameter must be set to 20 %.
- You must undertake all settings in manual mode.
- Each device needs an individual address on the CAN bus.

7.4.3.1 Checking circulating reactive current sensitivity

This section describes how to run the function test for circulating reactive current sensitivity.

1. Adjust both transformers in simplex mode to the same actual voltage by means of the on-load tap-changer.
 - ⇒ When both devices are in a state of equilibrium, then the value of the control deviation dV [%] is smaller than the set **bandwidth**. You can see this in the main screen if the mark for the measured voltage U_{actual} is within the bandwidth.
2. Connect the transformers in parallel and enable the parallel control.
 - ⇒ The two devices must still be in a state of equilibrium.
 - ⇒ The *Parallel operation* LED on the front panel is illuminated.
3. On one of the two transformers, raise the tap position of the on-load tap-changer by one setting; on the second transformer, lower the tap position of the on-load tap-changer by one setting.
 - ⇒ The two devices must still be in a state of equilibrium.
4. Adjust the **circulating reactive current sensitivity** until the result displayed exceeds the set value for the bandwidth by approx. 0.2 % to 0.3 %.
 - ⇒ The value for the result changes in the help text in the last line of the display.
5. Set the value given in the previous step for all devices in parallel operation.

6. Press **AUTO** to select auto mode for both devices.
 - ⇒ The devices return the on-load tap-changer units to the original tap positions.
 - ⇒ The function test for circulating reactive current sensitivity is complete.

If the earlier tap positions are not reached, increase the value of the circulating reactive current sensitivity [► Section , Page 103] parameter.

If one of the two on-load tap-changer units switches one or more tap positions higher and the other switches the same amount lower, you need to reduce the value of the circulating reactive current sensitivity [► Section , Page 103] parameter.

After you have set the **circulating reactive current sensitivity** parameter, continue with the circulating reactive current blocking function test described in the next section.

7.4.3.2 Checking circulating reactive current blocking

This section describes how to run the function test for circulating reactive current blocking.

1. Press **MANUAL** on one device to select manual mode.
2. Using manual control, adjust the relevant motor-drive unit upwards by the maximum permitted tap difference in operating positions between the parallel operating transformers (for example by 1 - 2 steps).



When setting the circulating reactive current blocking in the following process step, wait approx. 2 - 3 seconds between the individual steps.

3. Set the **parallel operation method** parameter to **circulating reactive current**.
4. The **circulating reactive current blocking** parameter should be reduced [► Section , Page 103] from the set value of 20 % in steps of 1 % until the *Parallel operation error: circulating reactive current limit exceeded* is displayed.
 - ⇒ The *Parallel operation* LED lights up when the circulating reactive current blocking limit is reached.
 - ⇒ Any further regulation is blocked.
5. After the set delay time for the parallel operation error message (time can be adjusted [► Section , Page 107]), the signaling relay X5:12 (default setting) is activated.
6. Increase the **circulating reactive current blocking** parameter again until the message *Parallel operation error: circulating reactive current limit exceeded* disappears.



7. Press **AUTO** to select auto mode.
 - ⇒ The motor-drive unit automatically returns to the original operating position.
8. Set the value determined for the **circulating reactive current blocking** on the devices in parallel operation as well.



If one or all devices indicate *Parallel operation error: circulating reactive current limit exceeded* although the control inputs are correctly connected for all the devices, then all the devices block.

This could be due to various causes. Further information is given in the chapter Troubleshooting [► Section 9, Page 130].

⇒ The function test for circulating reactive current blocking is complete.

7.4.3.3 Checking tap synchronization method

This section describes how to run the function test for tap synchronization (master/follower). If instances arise where a follower switches in the opposite direction to the master step change, then the setting for the tapping direction parameter on the follower must be changed from **Default** to **Swapped**.

NOTICE

Damage resulting from formation of circulating reactive current

If the parameters are not set correctly, damage may result from the formation of circulating reactive current and the resulting overload of transmission lines and transformers.

- Check transformer type plate.
- Set device parameters in accordance with transformer configuration.

Before starting the function test, you must carry out the following steps:

1. Assign the master function to one device.
2. Assign the follower function to the other devices.
3. Compare the tap position displays **3** of devices **1/2**. All devices must display the same tap position; if not, switch them into the same one.

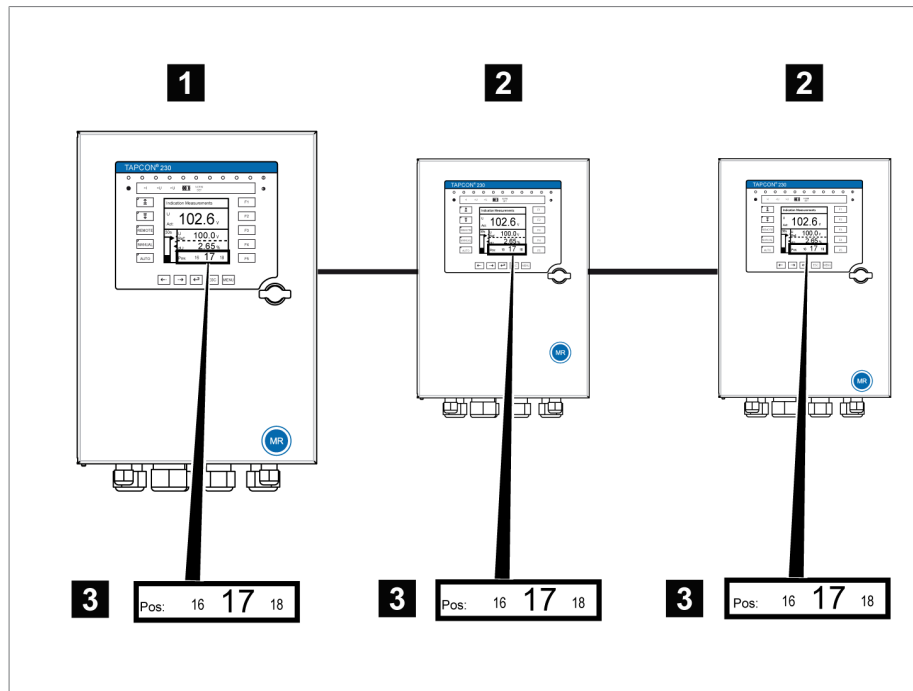







Figure 33: Comparing tap positions

1 Master	3 Tap position display
2 Follower	

To perform the function test, proceed as follows:

1. Press **MANUAL** on the follower to select manual mode.
2. If necessary, set the follower tapping direction.
3. Press **MANUAL** on the master to select manual mode.
4. Press **↑** or **↓** on the master to manually change the tap position.
5. Press **AUTO** on the follower to select auto mode.
 - ⇒ The follower follows the master's control command.
6. Press **AUTO** on the master to select auto mode.
7. Press **MANUAL** on the follower to select manual mode.
8. Press **↑** or **↓** on the follower to manually change the tap position.
 - ⇒ After expiry of the set delay time for parallel operation errors [► Section , Page 107], the *Tap difference to follower* error message is displayed in the main screen on the master.



9. Press  several times on the follower to manually increase the tap position by the number of permitted steps (maximum permitted tap difference) and then one more step.
 - ⇒ After expiry of the set delay time for parallel operation errors, the following error messages are displayed on the master: *Parallel operation error: tap difference to follower*
 - ⇒ After expiry of the set delay time for parallel operation errors, the following error messages are displayed on the follower: *Parallel operation error: permitted tap difference to master exceeded.*
10. Press  on the follower to select auto mode.
 - ⇒ There is no response. All devices remain blocked.
11. Press  on the master and follower to select manual mode.
12. Press  or  on the master and follower to manually set the desired step.



Because in parallel operation the tap positions of the transformers which are running in parallel are compared following the **Automatic tap synchronization** method, it is absolutely essential that these transformers have the same position designation and that the *Raise* and *Lower* signals produce the same voltage change in all transformers.

⇒ The function tests for the tap synchronization method are complete.

Installation and commissioning of the device is complete.



8 Operation

This chapter describes all the functions and setting options for the device.

8.1 Key lock

The device is equipped with a key lock to prevent unintentional operation. You can only set or change the parameters when the key lock is deactivated in manual mode.

Activating key lock

To activate the key lock, proceed as follows:

▶ Press **ESC** and **F5** at the same time.

⇒ A confirmation appears in the display for a brief period. The key lock is activated. Parameters can no longer be entered.

Deactivating key lock

To deactivate the key lock, proceed as follows:

▶ Press **ESC** and **F5** at the same time.

⇒ The key lock is deactivated. Parameters can be entered.

8.2 General

You can undertake general settings on the device in the **General** menu item.

- Language [▶ Section 7.2.1, Page 48]
- Regulator ID
- Baud rate (COM1 setting)
- Raise/Lower pulse duration
- Operations counter
- Display dimming
- Key lock
- Function monitoring
- Motor runtime
- Manual mode/auto mode
- Local/Remote

8.2.1 Setting device ID

You can use the device ID parameter to assign a 4-digit ID to the device. This ID is used to uniquely identify the device in the TAPCON®-trol software.

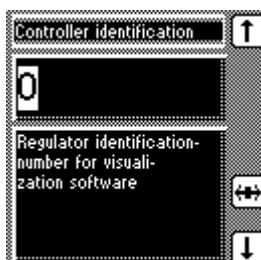

To set the device ID, proceed as follows:

1. **MENU** > **F4** Configuration > **F3** General > Press **→** until the desired parameter is displayed.
⇒ Regulator ID.
2. Press **F1** to change the first digit.
⇒ If you wish to enter a multi-digit sequence, proceed to step 3. If you do not wish to enter additional digits, proceed to step 7.
3. Press **F1** (digit > 9) until another digit position appears.
4. If necessary, press **F4** in order to highlight the digit position.
⇒ The required digit is highlighted and can be changed.
5. Press **F1** or **F5** to change the digit.
6. Repeat steps 3 to 5 until all required digits have been entered.
7. Press **↵**.
⇒ The device ID is set.

8.2.2 Setting the baud rate

You can use this parameter to set the COM1 interface's baud rate. You can select the following options:

- 9.6 kilobaud
- 19.2 kilobaud
- 38.4 kilobaud
- 57.6 kilobaud

To set the baud rate, proceed as follows:

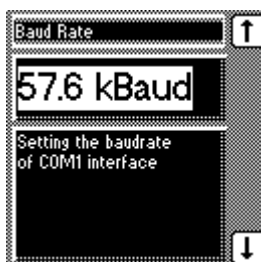

1. **MENU** > **F4** Configuration > **F3** General > Press **→** until the desired parameter is displayed.
⇒ Baud rate.
2. Press **F1** or **F5** to select the required baud rate.
3. Press **↵**.
⇒ The baud rate is set.

8.2.3 Setting the switching pulse time

You can use this parameter to set the duration of the switching pulse for the motor-drive unit.



If you set the switching pulse time to 0 s, the motor-drive unit is activated with a continuous signal. The signal then remains active for as long as the **↑** or **↓** keys are pressed.

Switching pulse in normal mode If you set the switching pulse time to 1.5 seconds for example, after the set **delay time T1** or **delay time T2** **1** there will be a switching pulse of 1.5 seconds **2**.

The waiting time between 2 consecutive switching pulses corresponds to the set **delay time T1** or **delay time T2** **1**.

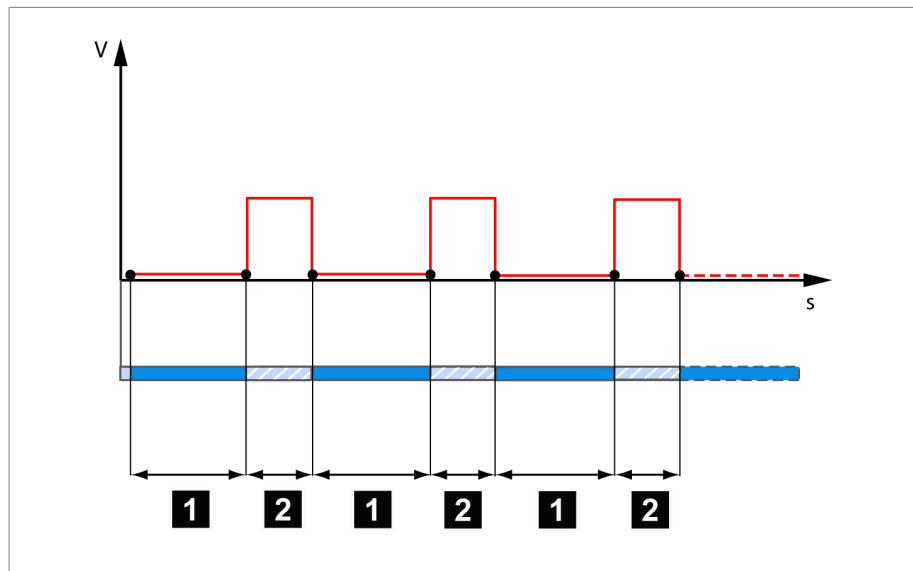

Figure 35: Switching pulse time in normal mode

1 Set delay time T1 or T2

2 Set switching pulse time (for example 1.5 seconds)



If the motor-drive unit does not start with the factory setting (1.5 seconds), you need to extend the raise switching pulse time / lower switching pulse time.

Switching pulse for rapid return control

If you set the raise switching pulse time or lower switching pulse time to 1.5 seconds, for example **2**, the next earliest switching pulse occurs in rapid return control mode **3** 1.5 seconds after the previous switching pulse ended.

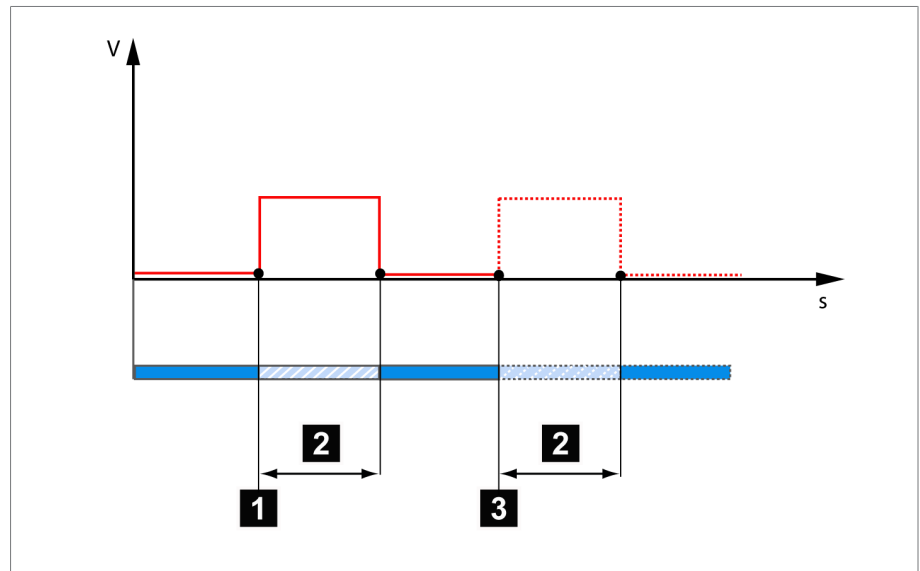
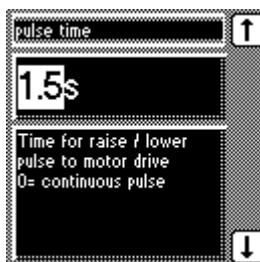

Figure 36: Switching pulse in rapid return control mode

- | | |
|--|--|
| 1 Start of first raise switching pulse/
lower switching pulse | 3 Earliest time for the next raise
switching pulse/lower switching
pulse (for example 1.5 seconds) |
| 2 Set switching pulse time (for exam-
ple 1.5 seconds) | |

To set the pulse duration, proceed as follows:



1. **MENU** > **F4** Configuration > **F3** General > Press **→** until the desired parameter is displayed.
⇒ R/L pulse duration.
 2. Press **F1** or **F5** to select the pulse duration you want.
 3. Press **←**.
- ⇒ The R/L pulse duration is now set.

8.2.4 Setting operations counter

The device's operations counter is automatically increased with every tap-change operation. You can use this parameter to set the number of tap-change operations for comparing with the operations counter of the motor-drive unit, for example.

To ensure correct operation counter function, the *Motor running* signal of the motor-drive unit must be connected with a configurable input (GPI 1...6) and then the **Motor running** function assigned to this input.

To set the operations counter, proceed as follows:



1. Press **MENU** > **F4** Configuration > **F3** General > Press **→** until the desired parameter is displayed.
⇒ Operations counter.
2. Press **F4** to highlight a digit.
⇒ The desired position is highlighted and the value can be changed.
3. Press **F1** to increase the value or **F5** to reduce it.
4. Press **↵**.
⇒ The operations counter is set.

8.2.5 Dimming display

You can use this parameter to activate or deactivate automatic display dimming. You can select the following options:

- On: The display is automatically dimmed if no key is pressed for 15 minutes. The display returns to full brightness by pressing any key.
- Off: Automatic display dimming is deactivated.



Activating this function extends the display's service life.

To activate/deactivate automatic display dimming, proceed as follows:

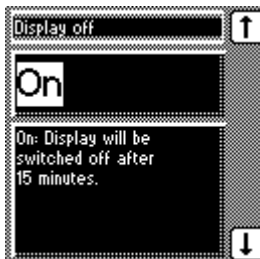

1. Press **MENU** > **F4** Configuration > **F3** General > **→** until the desired parameter is displayed.
⇒ Display off.
2. Press **F1** or **F5** to activate/deactivate automatic dimming.
3. Press **↵**.
⇒ Automatic dimming is set.

8.2.6 Activating/deactivating the automatic key lock

Activating this function automatically activates the key lock if no keys are pressed for 15 minutes. You can also lock the keys manually. This function can be deactivated as well.

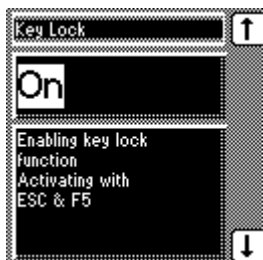

To set the automatic key lock, proceed as follows:

1. **MENU** > **F4** Configuration > **F3** General > Press **→** until the desired parameter is displayed.
⇒ Key lock
2. Press **F1** or **F5** to select **On** or **Off**.
3. Press **↵**.
⇒ Automatic key lock is set.

8.2.7 "Function monitoring" message for monitoring messages <30 V

By default, the *Function monitoring* message is activated for measured voltages. This message is issued as soon as the measured voltage is under 30 V for longer than the set signaling delay time.

Switched-off transformer

You can suppress the message with this parameter to prevent the message from being continuously issued when a transformer is shut off.

The device behaves as follows:

Parameter	Function
On	The <i>Function monitoring</i> message is issued after the configured delay time if the measured voltage is less than 30 V.
Off	The <i>Function monitoring</i> message is suppressed if the measured voltage is less than 30 V.

Table 8: Settings

Activate/deactivate message

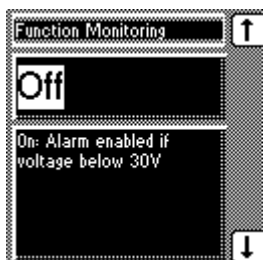

To activate/deactivate *function monitoring*, proceed as follows:

1. **MENU** > **F4** Configuration > **F3** General > Press **→** until the desired parameter is displayed.
⇒ Function monitoring
2. Press **F1** or **F5** to select **On** or **Off**.
3. Press **↵**.
⇒ The *Function monitoring* message for is activated/deactivated for measured voltages <30 V.

Setting delay time

You can configure the delay time after which the *Function monitoring* message is to be issued. If you select **0**, function monitoring is deactivated.

To set the delay time for the *Function monitoring* message, proceed as follows:



1. **MENU** > **F4** Configuration > **F3** General > Press **...** until the desired parameter is displayed.
⇒ Delay function monitoring
2. Press **F1** to increase the value or **F5** to reduce it.
3. Press **↵**.
⇒ The delay time for the *Function monitoring* message is set.

8.2.8 Setting motor runtime monitoring

You can use this motor runtime parameter to set the motor runtime. The motor-drive unit's runtime can also be monitored by the device. This function is used to identify motor-drive unit malfunctions during the tap-change operation and to trigger any actions needed.

Behavior The motor-drive unit issues the *Motor-drive unit running* signal during the tap-change operation. This signal is present until the tap-change operation is complete. The device compares the duration of this signal with the set motor runtime. If the set motor runtime is exceeded, the device triggers the following actions:

1. *Motor runtime monitoring* message is issued
2. Continuous signal via output relay *Motor-drive unit runtime exceeded* (optional)
3. Pulse signal via *Trigger motor protective switch* output relay (optional)

Parameterizing control input To use runtime monitoring, you need to correctly wire the corresponding control input and parameterize to *Motor running*. The motor runtime must also be set.

Wiring control input/output relay If you want to monitor the motor runtime, the device and motor-drive unit must be connected and parameterized as shown below.

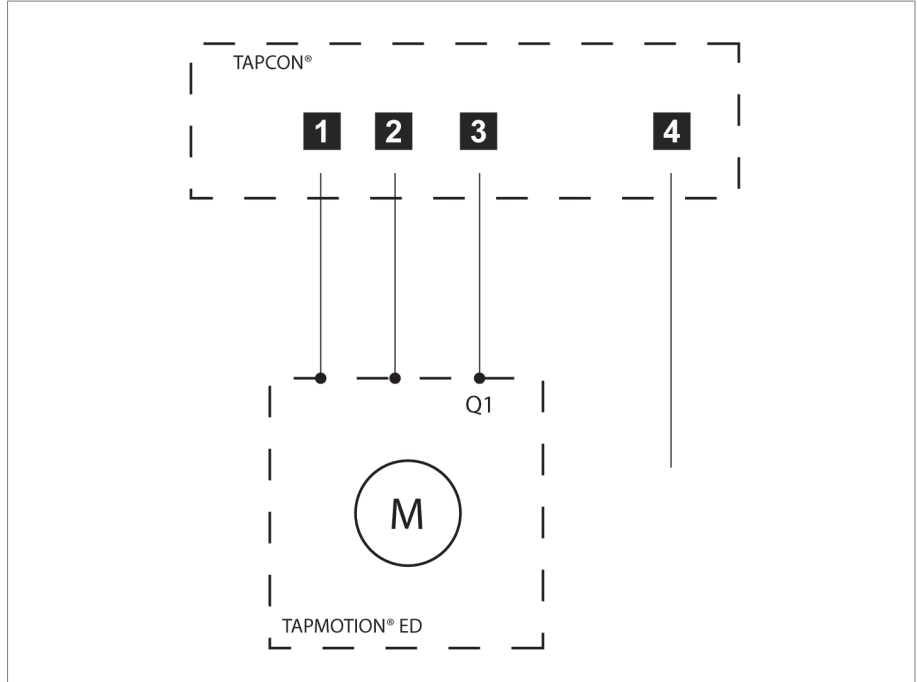

Figure 38: Wiring for motor runtime monitoring

1 <i>Motor running</i> control input I/O	3 <i>Motor protective switch tripped</i> GPO output relay (optional)
2 <i>Motor protective switch triggered</i> control input I/O (optional)	4 <i>Motor runtime exceeded</i> GPO output relay (optional)



If you want to use the output relay, the feedback from the motor-drive unit *Motor protective switch triggered* must be wired to a control input and parameterized. This message resets the *Motor runtime exceeded* output relay when the motor protective switch is switched back on and activates the *Motor protective switch triggered* message.



If the runtime monitoring is set to "0.0 s", this equates to it being switched off.

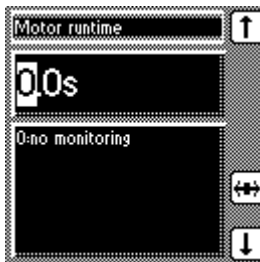

To set the motor runtime, proceed as follows:

1. **MENU** > **F4** Configuration > **F3** General > Press **→** until the desired parameter is displayed.
⇒ Motor runtime.
2. Press **F4** to highlight the position.
⇒ The desired position is highlighted and the value can be changed.
3. Press **F1** to increase the value or **F5** to reduce it.
4. Press **↵**.
⇒ The motor runtime is set.

8.2.9 Activate manual mode/auto mode

This parameter can be used to activate the *Manual* or *Automatic* operation modes. This parameter has the same functions as the **MANUAL** and **AUTO** keys.

Parameter	Function
Manual	Device is no longer controlling automatically. You can set or change parameters manually. You can control the motor-drive unit using the control panel.
Auto	The device is controlling the voltage automatically. You cannot set or change any parameters. You cannot control the motor-drive unit using the control panel.

Table 9: Adjustable parameters

To select the operating mode, proceed as follows:

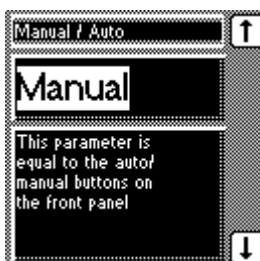

1. **MENU** > **F4** Configuration > **F3** General > Press **→** until the desired parameter is displayed.
⇒ Manual/Automatic
2. Press **F1** or **F5** to select the operating mode you want.
3. Press **↵**.
⇒ The operating mode is set.



8.2.10 Activating Local/Remote





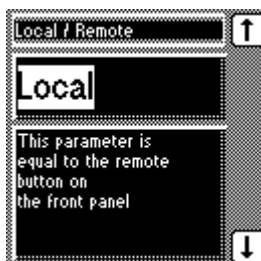

This parameter can be used to activate the *Local* or *Remote* operation modes. This parameter has the same functions as the  keys.

Parameter	Function
Local	You can operate the device using the control panel.
Remote	You can operate the device using an external control level.
	Manual operation is disabled.

Table 10: Adjustable parameters

To activate Manual or Automatic operating mode, proceed as follows:



1.  >  Configuration >  General > Press  until the desired parameter is displayed.
 2. Local/Remote
 3. Press  or  to select the operating mode you want.
 4. Press .
- ⇒ The operating mode is set.

8.2.11 Setting the COM1 password

You can use this parameter to enter a password for the COM1 front interface. This enables you to protect the device against unauthorized access via these interfaces. If a COM1 password is assigned, you must first enter the correct password to establish a connection via the interfaces.

Note the following information:

- The password must be at least 1 character long and must not exceed 8 characters. If you enter an empty password (only an end marker), then the COM1 password is deactivated.
- You can enter alphanumeric characters (A to Z, a to z, 0 to 9) and an end marker (space).
- If you want to use a password with fewer than 8 characters, you must select the end marker after the last character of your password.
- Once you save the password, the display changes to xxxxxxxx. The password is only displayed in plain text during text input.

Proceed as follows to set the COM1 password:



1. **MENU** > **F4** Configuration > **F3** General > Press **→** until the desired parameter is displayed.
⇒ COM1 password.
2. Enter the current COM1 password. Press **F1** or **F5** to change a character and **F4** to select the next character.
3. Press **↵**.
⇒ The *Parallel operation active* LED flashes. You can establish a connection via the front interface or enter a new password.
4. Press **F1** or **F5** to change a character and **F4** to select the next character.
5. Press **↵**.
⇒ The COM1 password is set. The display changes to xxxxxxxx.

8.2.12 Setting the password duration

You can use this parameter to set the period for which the password is active once it has been entered. If the password is active, the *Parallel operation active* LED flashes.



If you establish a connection via the COM1 front interface, the password remains active for as long as data is being transferred via the interface. The set password duration expires the moment that no more data is transmitted.

To set the password duration, proceed as follows:



1. **MENU** > **F4** Configuration > **F3** General > Press **→** until the desired parameter is displayed.
⇒ Password duration.
2. Press **F1** or **F5** to increase or decrease the value.
3. Press **↵**.
⇒ The password duration is set.

8.3 NORMset

NORMset mode is used for quickly starting voltage regulation. In NORMset mode, the bandwidth and delay time parameters are automatically adapted to the requirements of the grid.

To start NORMset mode, you must set the following parameters:

- Normset activation
- Desired value 1



- Primary voltage
- Secondary voltage



Line drop compensation cannot be performed in NORMset mode.

Set the following parameters to operate the device in NORMset mode.

Activating/deactivating NORMset

You can use this parameter to activate NORMset mode.



A manual tap-change operation is required to activate NORMset. This is how the voltage regulator determines the bandwidth required.

If the transformer is switched off, another manual tap-change operation is required.

To activate/deactivate NORMset mode, proceed as follows:

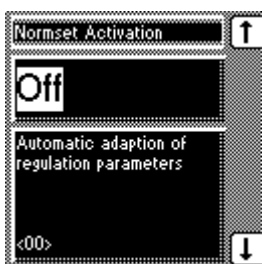

1. **MENU** > **F2** NORMset
⇒ NORMset activation.
 2. Press **F1** or **F5** to activate NORMset by selecting **On** or to deactivate NORMset by selecting **Off**.
 3. Press **←**.
- ⇒ NORMset is activated/deactivated.

Setting the primary voltage

With this parameter, you can set the voltage transformer's primary voltage.

To set the primary voltage, proceed as follows:

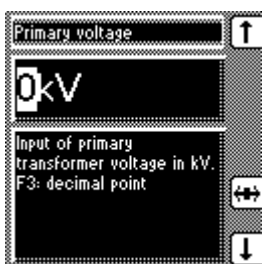

1. **MENU** > **F2** NORMset > Press **→** until the desired parameter is displayed.
⇒ Primary voltage.
 2. Press **F1** to increase the value or **F5** to reduce it.
 3. Press **←**.
- ⇒ The primary voltage is set.

Setting the secondary voltage

With this parameter, you can set the voltage transformer's secondary voltage.

To set the secondary voltage, proceed as follows:

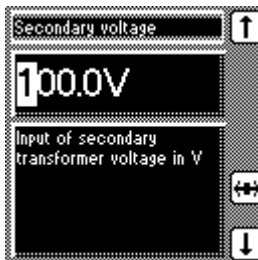

1. **MENU** > **F2** NORMset > Press **→** until the desired parameter is displayed.
⇒ Secondary voltage.
2. Press **F1** to increase the value or **F5** to reduce it.
3. Press **↵**.
⇒ The secondary voltage is set.

Setting desired value 1

With this parameter, you can set the desired value for automatic voltage regulation. You can enter the desired value in V or in kV. If you enter the desired value in V, the value relates to the voltage transformer's secondary voltage. If you set the desired value in kV, the value relates to the voltage transformer's primary voltage.



Settings in kV are only possible if you have previously entered the parameters for primary and secondary voltage.

To set the desired value, proceed as follows:

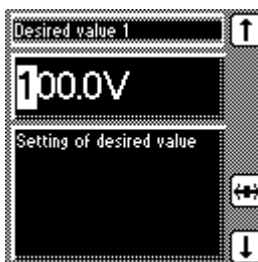

1. **MENU** > **F2** NORMset > Press **→** until the desired parameter is displayed.
⇒ Desired value 1.
2. Press **F1** to increase the value or **F5** to reduce it.
3. Press **↵**.
⇒ The desired value is set.

8.4 Control parameters

All of the required for the regulation function are described in this section. For voltage regulation, you can set the following parameters:

- Desired values 1...3
- Bandwidth
- Delay time T1
- Control response T1
- Delay time T2

For voltage regulation, you can set delay time T1 and also delay time T2. The following sections describe how the regulation function responds in both cases:



Behavior only with delay time T1

If the measured voltage U_{actual} **5** is within the set bandwidth **6**, no control commands are issued to the motor-drive unit for the tap-change operation. Control commands will also not be issued to the motor-drive unit if the measured voltage returns to the tolerance bandwidth **6** within the set delay time $T1$ **4**. However, if the measured voltage deviates from the set bandwidth for a long period **C**, a tap-change command **D** occurs after expiration of the set delay time $T1$. The on-load tap-changer carries out a tap-change in a raise or lower direction to return to the tolerance bandwidth.

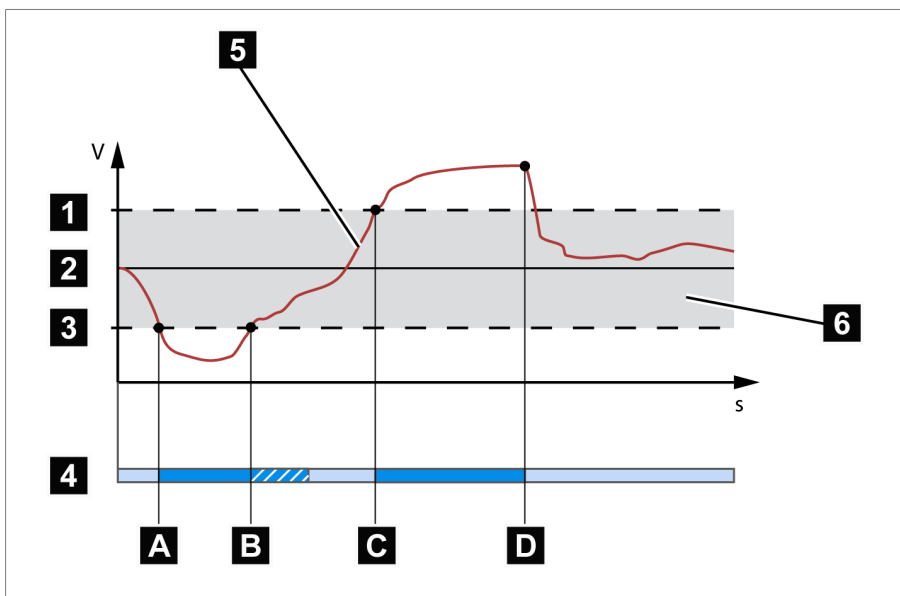

Figure 41: Behavior of the regulation function with delay time $T1$

1 + B %: Upper limit	4 Set delay time $T1$
2 $U_{desired}$: Desired value	5 U_{actual} : Measured voltage
3 - B %: Lower limit	6 B%: Tolerance bandwidth
A U_{actual} is outside the bandwidth. Delay time $T1$ starts.	B U_{actual} is within the bandwidth before delay time $T1$ is complete.
C U_{actual} is outside the bandwidth. Delay time $T1$ starts.	D U_{actual} is still outside the bandwidth when delay time $T1$ is complete. Tap-change operation is initiated.

Behavior with delay times $T1$ and $T2$

Delay time $T2$ can be used to correct major control deviations more quickly. Ensure that you set a lower value in the "Delay time $T2$ " parameter than in the "Delay time $T1$ " parameter.

If the measured voltage U_{actual} **5** deviates from the set bandwidth for a long period **A**, a control impulse is output to the motor-drive unit after the set delay time $T1$ **B**. If the measured voltage U_{actual} is still outside the bandwidth,

delay time T2 **B** starts once delay time T1 is complete. Once delay time T2 is complete, a control impulse is again output to the motor-drive unit for the tap change **C** to return to the tolerance bandwidth.

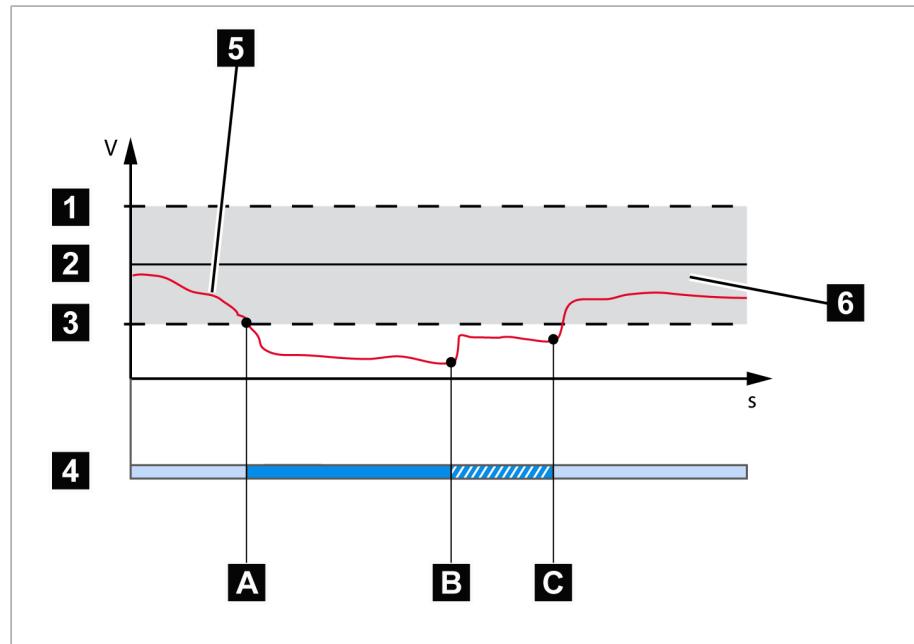

Figure 42: Behavior of the regulation function with delay times T1 and T2

1 + B %: Upper limit	4 Set delay times T1 and T2.
2 U_{desired} : Desired value	5 U_{actual} : Measured voltage
3 - B %: Lower limit	6 B%: Tolerance bandwidth
A U_{actual} is outside the bandwidth. Delay time T1 starts.	B Delay time T1 complete. Tap change triggered.
C Delay time T2 complete. Tap change triggered.	

The following sections describe how to set the relevant control parameters.

8.4.1 Setting desired value 1...3

You can use this parameter to set up to 3 desired voltage values U_{Ref} . The desired voltage value is specified as a fixed value. The desired value 1 is the default desired value. Desired values 2 and 3 are activated if there is a continuous signal at factory-preset control inputs X4:17 or X4:18 provided you have programmed these previously. If there is a signal at several control inputs at the same time, desired value 2 is activated.

Options for setting the desired values

The device provides the following ways of changing the desired voltage value during operation:

- Using the control parameters menu item via the operating screen
- Using binary inputs
- Using control system protocols if a communication card is ready for operation

Reference of kV and V for voltage transformer

Desired values set in kV refer to the primary voltage of the voltage transformer. Desired values set in V refer to the secondary voltage of the voltage transformer. The transformer data must be entered correctly for this display.

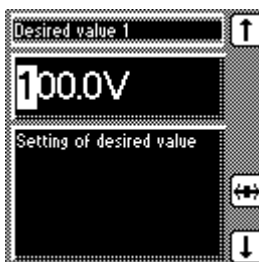

To set the desired value, proceed as follows:

1. **MENU** > **F3** Control parameter > **F2** voltage regulator > Press **→** until the desired parameter is displayed.
2. If you have already entered the transformer data, press **F3** to select the unit you want: "V" or "kV".
3. Press **F4** to highlight the position.
⇒ The desired position is highlighted and the value can be changed.
4. Press **F1** to increase the value or **F5** to reduce it.
5. Press **↵**.
⇒ The desired value is set.

8.4.2 Selecting a desired value

You can use this parameter to select the active desired value 1, 2 or 3.



If you select the desired value using appropriately configured GPIs, this parameter's setting is ignored. Refer to the Configuration [▶ Section 8.11, Page 116] section for more information about GPI configuration.

Proceed as follows to select a desired value:

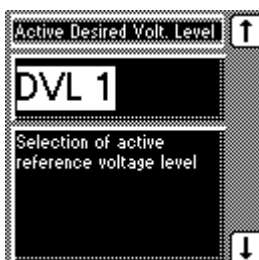

1. **MENU** > **F3** Control parameter > **F2** Voltage regulation > Press **→** until the desired parameter is displayed.
⇒ Desired value selection
2. Press **F1** or **F5** to select an active desired value.
3. Press **↵**.
⇒ The selected desired value is active.

8.4.3 Bandwidth

You can use this parameter to set the maximum permissible deviation in measured voltage U_{Act} . The deviation relates to the activated desired value. The following sections describe how you determine and set the bandwidth required.

8.4.3.1 Determining bandwidth

In order to set the correct value, the transformer's step voltage and nominal voltage must be known.

Too small/large a bandwidth

You have to set the bandwidth in such a way that the output voltage of the transformer (U_{Act}) returns to within the specified tolerance bandwidth after the tap change. If too small a bandwidth is defined, the output voltage exceeds the bandwidth selected and the device immediately issues a tap-change command in the opposite direction. If a very large bandwidth is selected, this results in a major control deviation.

The following value is recommended for the bandwidth setting:

$$[\pm B\%] \geq 0,6 \cdot \frac{U_{n-1} - U_n}{U_{nom}} \cdot 100\%$$

Figure 44: Recommended bandwidth

U_{n-1}	Step voltage of tap position n-1
U_n	Step voltage of tap position n
U_{nom}	Nominal voltage

The following transformer values are used to determine the recommended bandwidth:

Nominal voltage $U_{nom} = 11,000 V$

Step voltage in tap position 4 $U_{Step4} = 11,275 V$

Step voltage in tap position 5 $U_{Step5} = 11,000 V$



$$[\pm B\%] \geq 0,6 \cdot \frac{U_{Step4} - U_{Step5}}{U_{nom}} \cdot 100\%$$

$$[\pm B\%] \geq 0,6 \cdot \frac{11275 V - 11000 V}{11000 V} \cdot 100\%$$

$$[\pm B\%] \geq 1,5\%$$

The following section describes how you can set the bandwidth.

8.4.3.2 Setting the bandwidth

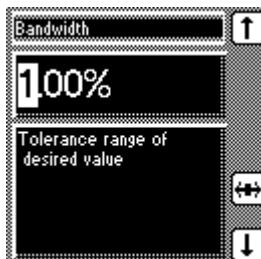

To enter the determined bandwidth, proceed as follows:

1. **MENU** > **F3** Parameter > **F2** Control parameter > Press **→** until the desired parameter is displayed.
 2. Press **F4** to highlight the position.
⇒ The desired position is highlighted and the value can be changed.
 3. Press **F1** to increase the value or **F5** to reduce it.
 4. Press **←**.
- ⇒ The bandwidth is set.

8.4.3.3 Visual display

The deviation from the set bandwidth is shown visually in the device's display. The measured voltage **3** highlighting shows whether the measured voltage is above, within or below the set bandwidth **1**. Progress of delay time T1 is indicated by the gradual filling of the time bar **2**. The seconds display **5** above this indicates the remaining delay time T1.

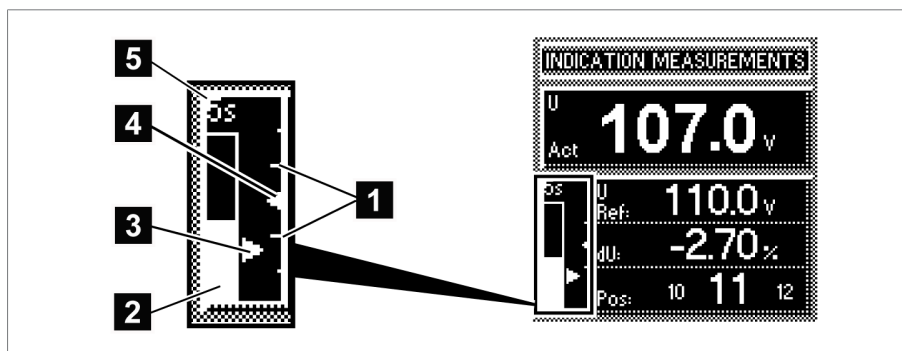
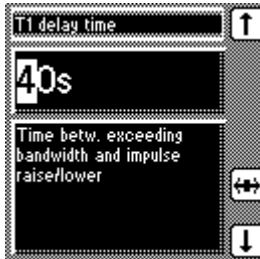

Figure 45: Visual display of deviation from desired value

1 Bandwidth (upper and lower limit)	4 Desired voltage value U_{desired}
2 Time bar for delay time T1	5 Remaining delay time T1
3 Measured voltage U_{actual}	

8.4.4 Setting delay time T1

Use this parameter to set delay time T1. This function delays the issuing of a tap-change command for a defined period. This prevents unnecessary tap-change operations if the tolerance bandwidth is exited.



To set the delay time T1, proceed as follows:

1. **MENU** > **F3** Parameter > **F2** Control parameter > Press **→** until the desired parameter is displayed.
2. Press **F4** to highlight the position.
⇒ The desired position is highlighted and the value can be changed.
3. Press **F1** to increase the time or **F5** to reduce it.
4. Press **↵**.
⇒ The delay time T1 is set.

8.4.5 Setting control response T1

The control response T1 can be set to linear or integral.

Linear control response T1 With linear control response, the device responds with a constant delay time regardless of the control deviation.

Integral control response T1 With integral control response, the device responds with a variable delay time depending on the control deviation. The greater the control deviation (ΔU) in relation to the set bandwidth (B), the shorter the delay time. The delay time can therefore be reduced down to 1 second. This means that the device responds faster to large voltage changes in the grid. Regulation accuracy improves as a result but the frequency of tap-changes increases too.

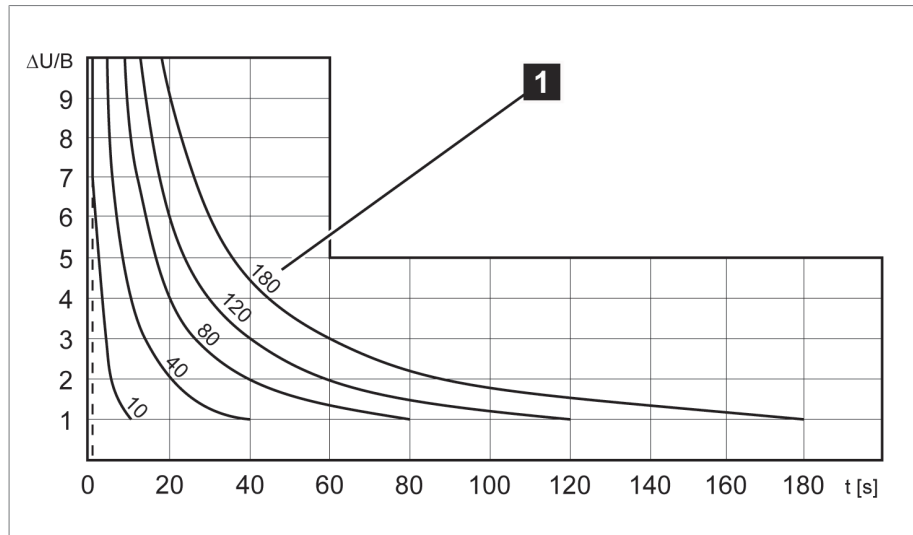
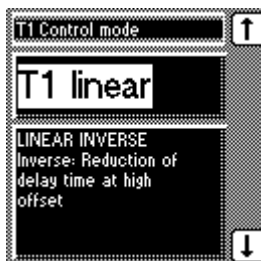

Figure 46: Diagram showing integral control response

$\Delta U/B$ Control deviation " ΔU " as % of desired value as ratio to the set bandwidth " B " as % of desired value

1 "Delay time T1" parameter



To set the control response T1, proceed as follows:

1. **MENU** > **F3** Parameter > **F2** Control parameter > Press **→** until the desired parameter is displayed.
2. Press **F1** or **F5** to set the response you want.
3. Press **←**.

⇒ The control response T1 is set.

8.4.6 Setting delay time T2

With this parameter, you can set delay time T2. Delay time T2 is used to compensate for large control deviations faster.

The delay time T2 only takes effect if more than one tap-change operation is required to return the voltage to within the set bandwidth. The first output pulse occurs after the set delay time T1. After the set tap-change delay time T2 has elapsed, additional pulses occur in order to correct the existing control deviation.

The following requirements must be noted to set delay time T2:

- The delay time T2 must be greater than the switching pulse time.
- The delay time T2 must be greater than the maximum operating time of the motor-drive unit.
- The delay time T2 must be less than the value set for delay time T1.

To set the delay time T2, proceed as follows:



1. **MENU** > **F3** Parameter > **F2** Control parameter > Press until the desired parameter is displayed.
⇒ Delay time T2.
2. Press **F1** to increase the time or **F5** to reduce it.
3. Press **←**.

⇒ The delay time T2 is set.

Activating/deactivating delay time T2

To activate/deactivate delay time T2, proceed as follows:

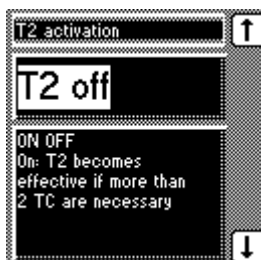

1. **MENU** > **F3** Parameter > **F2** Control parameter > Press **→** until the desired parameter is displayed.
⇒ T2 activation.
2. Press **F5** or **F1** to activate/deactivate T2.
3. Press **←**.

⇒ The delay time T2 is activated/deactivated.



8.5 Limit values

In the Limit values menu item, you can set all the parameters needed for limit value monitoring as relative or absolute values. You can set three limit values:

- Undervoltage U<
- Overvoltage U>
- Overcurrent I>

Limit value monitoring is used to reduce damage to the system periphery. The following sections describe how you can set the parameters.

8.5.1 Setting undervoltage monitoring U<

You can use these parameters to set the limit values for an undervoltage. Undervoltage monitoring prevents tap-change operations if there is a power cut.



Behavior If the measured voltage U_{actual} **7** falls below the set limit value **4**, the red LED $U<$ lights up. The switching pulses to the motor-drive unit are blocked at the same time provided you have activated the blocking undervoltage $U<$ parameter. Once the set signaling delay time [► Section , Page 82] **6** has passed, the signaling relay activates. The *Undervoltage* $U<$ **B** message appears in the display. The message is reset as soon as the measured voltage U_{actual} again exceeds the limit value for undervoltage **E**. If the measured voltage U_{actual} falls below 30 V **C** (for example when the transformer is switched off), the *undervoltage* message is also displayed. You can however suppress [► Section , Page 83] this message.

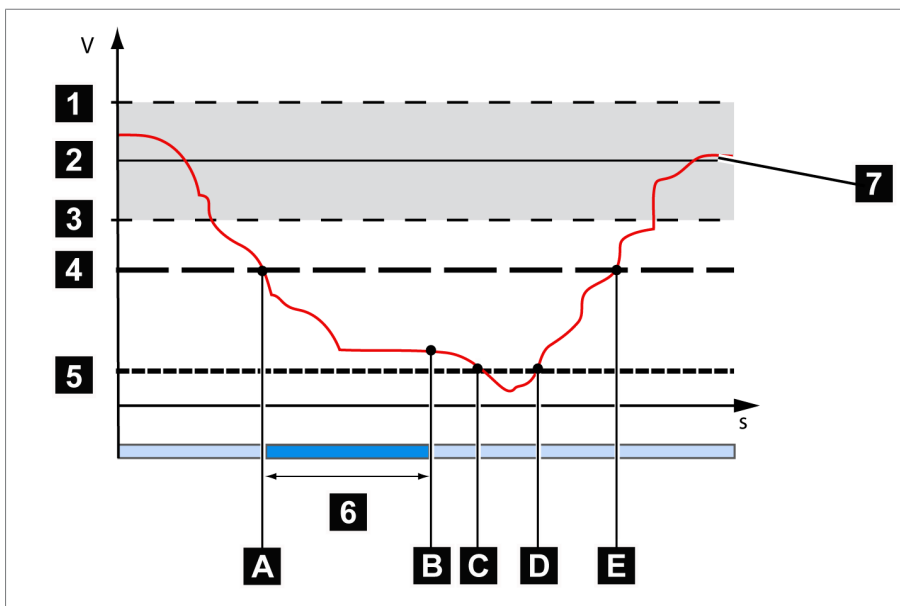
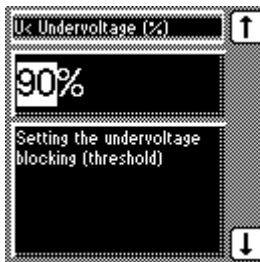

Figure 47: Response to value falling below limit value

1 + B%: Upper limit	7 U_{actual} : Measured voltage
2 U_{desired} : Desired value	A Value falls below limit value
3 - B%: Lower limit	B <i>Undervoltage</i> $U<$ message is displayed
4 Set limit value for undervoltage $U<$	C Voltage falls below 30 V
5 Limit value for suppressing alarms below 30 V	D Voltage exceeds 30 V again
6 Set signaling delay time for limit value for undervoltage $U<$	E Value exceeds limit value

Setting undervoltage monitoring $U<$ in %

Use the parameter to set the limit value as a relative value.



To set the limit value for undervoltage U< as %, proceed as follows:

1. **MENU** > **F3** Control parameter > **F3** Limit values > Press **→** until the desired parameter is displayed.
⇒ U< Undervoltage (%)
 2. Press **F1** to increase the value or **F5** to reduce it.
 3. Press **↵**.
- ⇒ The limit value for undervoltage U< is set.

Setting signaling delay for undervoltage U<

You can use this parameter to set the delay time after which the *Undervoltage* relay is to activate and the event message appear on the display. This can be used to prevent messages from being issued when the value briefly falls below the limit value. The undervoltage LED always lights up immediately regardless.



To set the delay time for this message, proceed as follows:

1. **MENU** > **F3** Control parameter > **F3** Limit values > Press **→** until the desired parameter is displayed.
⇒ U< Delay
 2. Press **F4** to highlight the position.
⇒ The desired position is highlighted and the value can be changed.
 3. Press **F1** to increase the time or **F5** to reduce it.
 4. Press **↵**.
- ⇒ The signaling delay time for undervoltage U< is set.

Activating/deactivating undervoltage blocking

You can use this parameter to set how the device behaves if the voltage falls below the undervoltage limit. You can select the following options:

Setting	Function
On	Automatic regulation is blocked.
Off	Automatic regulation remains active.

Table 11: Behavior

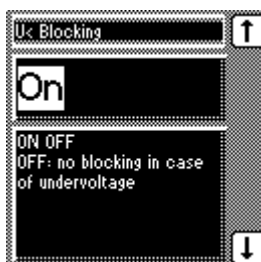

To activate/deactivate the undervoltage blocking, proceed as follows:

1. **MENU** > **F3** Control parameter > **F3** Limit values > Press **...** until the desired parameter is displayed.
⇒ U< blocking.
 2. Press **F1** for **On** setting or **F5** for **Off** setting.
 3. Press **←**.
- ⇒ Undervoltage blocking is activated/deactivated.

Activating/deactivating message for voltages below 30 V

You can use this parameter to set whether the *Undervoltage* message is to be suppressed at a measured value of less than 30 V. This setting is used to ensure that no event message appears when the transformer is switched off. You can select the following options:

Setting	Function
On	The <i>Undervoltage</i> message is also displayed when the measured value is less than 30 V.
Off	The <i>Undervoltage</i> message is no longer displayed when the measured value is less than 30 V.

Table 12: Response

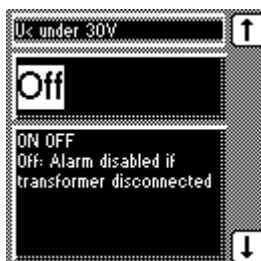

To activate/deactivate the message, proceed as follows:

1. **MENU** > **F3** Control parameter > **F3** Limit values > Press **...** until the desired parameter is displayed.
⇒ U< also under 30 V.
 2. Press **F1** for **On** setting or **F5** for **Off** setting.
 3. Press **←**.
- ⇒ The message is activated/deactivated.

8.5.2 Setting overvoltage monitoring U>

You can use these parameters to set the limit values for overvoltage monitoring. This overvoltage monitoring triggers tap-change operations to return to the desired operating status. If the operating status can no longer be corrected, a message is triggered by the *Function monitoring* relay.

Response to high-speed return

If the measured voltage U_{actual} exceeds the set limit value **1**, the red LED $U>$ and associated signaling relay activate. The *Overvoltage U>* message appears in the display. At the same time, the high-speed return function is activated without delay time T1. Once the set switching pulse time **5** has passed, the tap position is lowered **C** by activating the motor-drive unit until the measured voltage U_{actual} **6** again falls below the limit value **B**. The *Overvoltage U>* message is reset.

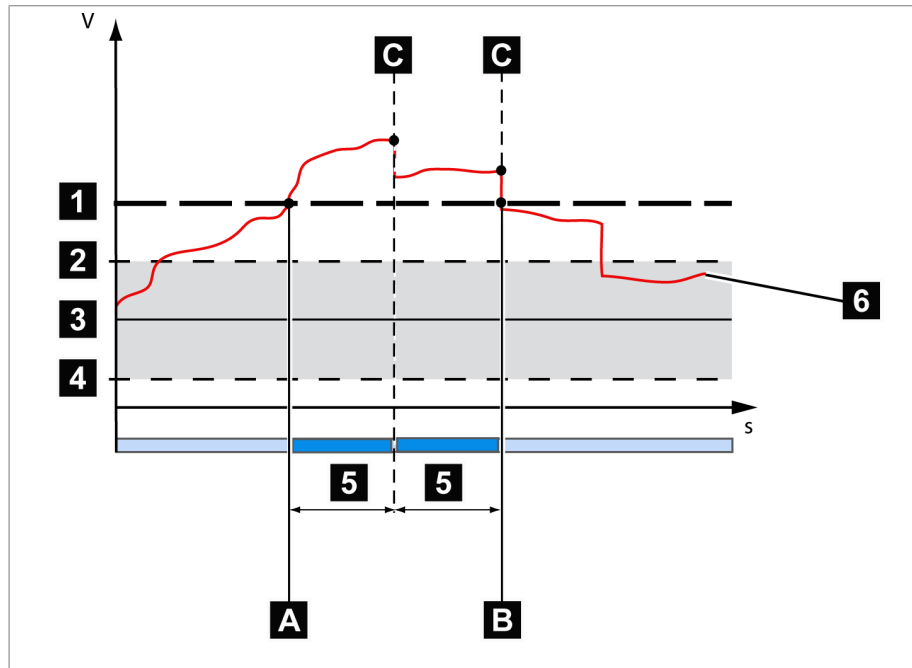

Figure 48: Response to limit value being exceeded

1 Set limit value for overvoltage $U>$	6 U_{actual} : Measured voltage
2 + B %: Upper limit	A Value exceeds limit value
3 U_{desired} : Desired value	B Value falls below limit value
4 - B %: Lower limit	C High-speed return is started (lower tap-change)
5 Set switching pulse time	

Response to overvoltage blocking

If you activated the overvoltage blocking, all switching pulses to the motor-drive unit are blocked when a limit value is exceeded. At the same time, the red LED $U>$ lights up and the *Overvoltage U>* message is displayed. As soon as the measured voltage U_{actual} has again fallen below the limit value, blocking and the message are reset.

The following sections describe how you can set the parameters for the overvoltage $U>$ limit value.



Setting overvoltage U> as %

The limit value is entered as a relative value (%) of the set desired value. To set the limit value, proceed as follows:

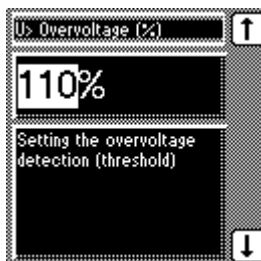

1. **MENU** > **F3** Control parameter > **F3** Limit values > Press **→** until the desired parameter is displayed.
⇒ U> Overvoltage (%)
 2. Press **F1** to increase the value or **F5** to reduce it.
 3. Press **↵**.
- ⇒ The limit value is set.

Activating overvoltage blocking/high-speed return

You can use this parameter to set how the device responds to overvoltage. The following settings are possible:

Setting	Behavior
On	During overvoltage, the device blocks all switch pulses to the motor-drive unit.
Off	In the event of overvoltage, a high-speed return is undertaken until the value again falls below the limit value.

Table 13: Possible settings

To set the device's response to overvoltage, proceed as follows:

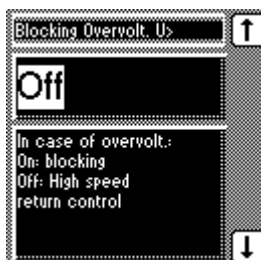

1. **MENU** > **F3** Control parameter > **F3** Limit values > Press **→** until the desired parameter is displayed.
⇒ Overvolt. blocking U>.
 2. Press **F1** or **F5** to set the option you want.
 3. Press **↵**.
- ⇒ The response is set.

8.5.3 Setting overcurrent monitoring I>

You can use this parameter to set the limit value for overcurrent to prevent tap-change operations in the event of excess load currents.

If the measured current exceeds the set limit value, the red LED I> lights up. The *Overcurrent* message appears in the display. The device's output pulses are blocked at the same time.

Setting overcurrent I> as %

To set the limit value I> overcurrent for overcurrent blocking, proceed as follows:

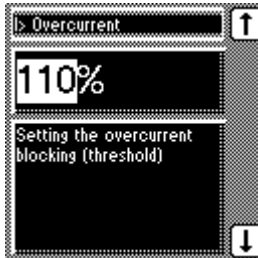

1. **MENU** > **F3** Control parameter > **F3** Limit values > Press **→** until the desired parameter is displayed.
⇒ Overcurrent I>
 2. Press **F1** to increase the value or **F5** to reduce it.
 3. Press **↵**.
- ⇒ The limit value is set.

Activating/deactivating overcurrent blocking

To activate/deactivate overcurrent blocking, proceed as follows:



1. **MENU** > **F3** Control parameter > **F3** Limit values > Press **→** until the desired parameter is displayed.
⇒ Blocking Overcurr. I>
 2. Press **F1** or **F5** to activate (**ON**)/deactivate (**OFF**) overcurrent blocking.
 3. Press **↵**.
- ⇒ The overcurrent blocking is activated/deactivated.

8.5.4 Set undercurrent monitoring I<

These parameters are used to set undercurrent monitoring. As soon as the measured current falls below the set limit value, control is blocked.

Setting undercurrent I<

To set the limit value for undercurrent monitoring, proceed as follows:

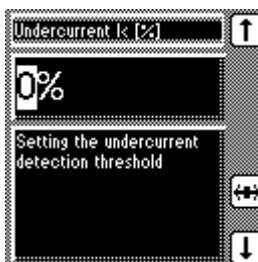

1. **MENU** > **F3** Control parameter > **F3** Limit values > Press **→** until the desired parameter is displayed.
⇒ Undercurrent I< [%]
 2. Press **F1** to increase the value or **F5** to reduce it.
 3. Press **↵**.
- ⇒ The I< undercurrent limit value is set.



Activating/deactivating I< undercurrent blocking

To activate/deactivate undercurrent monitoring, proceed as follows:



1. **MENU** > **F3** Control parameter > **F3** Limit values > Press **→** until the desired parameter is displayed.
⇒ Blocking undercurrent I>.
2. Press **F1** or **F5** to activate (ON)/deactivate (OFF) undercurrent blocking.
3. Press **←**.

⇒ The I< undercurrent blocking is activated/deactivated.

8.5.5 Activate/deactivate active power monitoring

This parameter can be used to set active power monitoring. If blocking is activated, the control is blocked if a negative active power flow is detected. However, this is only possible if the current transformer connection is connected and correctly set. When regulator blocking is deactivated, then the sign of the active power does not affect the regulation.

To activate/deactivate regulator blocking, proceed as follows:



1. **MENU** > **F3** control parameter > **F4** Compensation > Press **→** until the desired parameter is displayed.
⇒ Neg. active power block.
2. Press **F1** or **F5** to select the option you want.
3. Press **←**.

⇒ Blocking the regulator with negative active power is activated/deactivated.

8.5.6 Permitted tap positions

You can use the parameters described below to restrict the permissible range of tap positions in auto mode. If you activate this function, the device does not switch to tap positions outside the set limits in auto mode.



In manual mode, for manual tap changes on the motor-drive unit or for remote tap changes via a SCADA system, monitoring of the step limits is not active. This may result in the set limits being exceeded.

When switching from manual to auto mode, the tap changer should be within the permitted tap positions.

8.5.6.1 Setting the lowest tap position blocking limit

You can define a lower tap position blocking limit to limit the number of tap positions available in operation. When the tap position defined as lower tap position blocking limit is reached, tap position blocking is activated. This prevents any further tap change downwards.

To define the lower tap position blocking limit, proceed as follows:

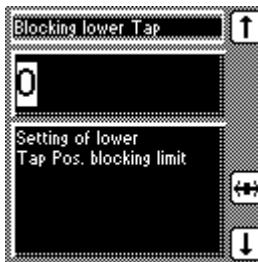

1. **MENU** > **F4** Configuration > **F5** Continue > **F5** Continue > **F3** Tap position > Press **→** until the desired parameter is displayed.
⇒ Lowest tap position
2. Press **F4** to highlight a digit.
⇒ The desired position is highlighted and the value can be changed.
3. Press **F1** to increase the value or **F5** to reduce it.
4. Press **↵**.
⇒ The lower tap position blocking limit is defined.

8.5.6.2 Setting highest tap position blocking limit

You can define an upper tap position blocking limit to limit the number of tap positions available in operation. When the tap position defined as the upper tap position blocking limit is reached, tap position blocking is activated. This prevents any further tap change upwards.

To define the upper tap position blocking limit, proceed as follows:

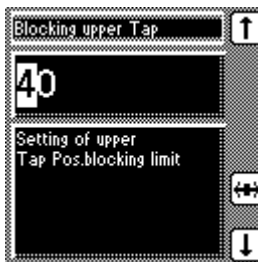

1. **MENU** > **F4** Configuration > **F5** Continue > **F5** Continue > **F3** Tap position > Press **→** until the desired parameter is displayed.
⇒ Highest tap position
2. Press **F4** to highlight a digit.
⇒ The desired position is highlighted and the value can be changed.
3. Press **F1** to increase the value or **F5** to reduce it.
4. Press **↵**.
⇒ The upper blocking limit is defined.











8.5.6.3 Setting the tap position blocking mode

You can set the tap position blocking mode in relation to the upper and lower tap position blocking limits:

Setting	Behavior
Off	The tap position blocking mode is deactivated
Directional	During raise and lower tap changes, the device blocks as soon as the defined upper/lower tap position limit is reached or exceeded. Further tap changes are prevented.
Non-directional	The device blocks in both directions as soon as the defined lower/upper tap position limit is reached or exceeded. Further tap changes are prevented.

Table 14: Tap position blocking mode

To set the tap position blocking mode, proceed as follows:

- ✓ Press  to select manual mode.
 - ✓ Press  to change back manually into the defined tap position limits.
1.  >  Configuration >  Continue >  Continue >  Tap position > Press  until the desired parameter is displayed.
⇒ Tap pos. blocking mode
 2. Press  or  to set the option you want.
 3. Press .
- ⇒ The tap position blocking mode is set.

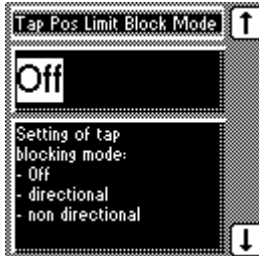

8.6 Compensation

You can use the "Compensation" function to compensate for the load-dependent voltage drop between the transformer and consumer. The device provides 2 methods of compensation for this purpose:

- R&X compensation (line drop compensation)
- Z compensation

8.6.1 Line drop compensation

R&X compensation (LDC) requires exact cable data. Line voltage drops can be compensated very accurately using LDC.

To set R&X compensation correctly, you need to calculate the ohmic and inductive voltage drop in V with reference to the secondary side of the voltage transformer. You also need to correctly set the transformer circuit used.

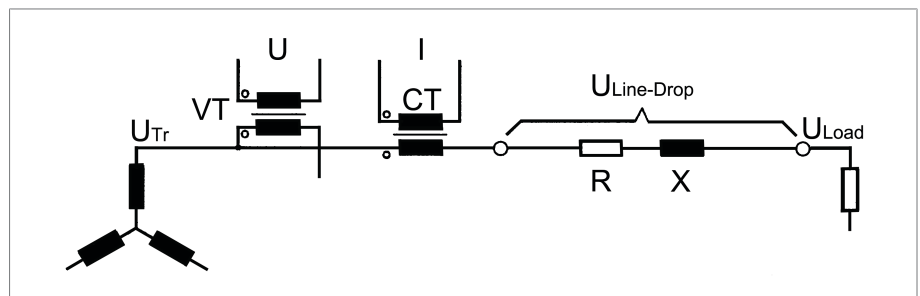

Figure 51: Equivalent circuit

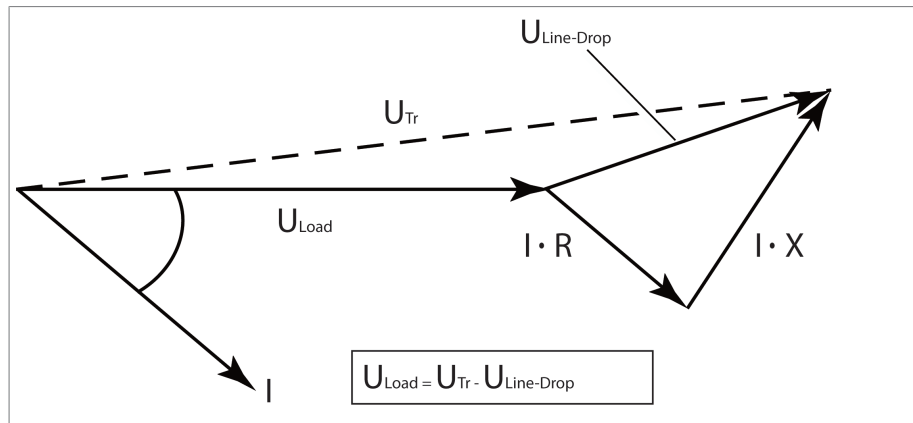

Figure 52: Phasor diagram

You can calculate the ohmic and inductive voltage drop using the following formulas. This voltage drop calculation relates to the relativized voltage on the secondary side of the voltage transformer.

Formula for calculating the ohmic voltage drop:

$$U_r = I_N \cdot \frac{k_{CT}}{k_{VT}} \cdot r \cdot L \cdot K \text{ [V]}$$

Formula for calculating the inductive voltage drop:

$$U_x = I_N \cdot \frac{k_{CT}}{k_{VT}} \cdot x \cdot L \cdot K \text{ [V]}$$

U_r	Voltage drop in V due to ohmic line resistance
U_x	Voltage drop in V due to inductive line resistance
I_N	Nominal current (amps) of selected current-transformer connection on device: 1 A; 5 A
k_{CT}	Current transformer ratio
k_{VT}	Voltage transformer ratio
r	Ohmic resistance load in Ω /km per phase
x	Inductive resistance load in Ω /km per phase
L	Length of line in km
K	Nominal current factor

Selecting the line drop compensation

To select the line drop compensation, proceed as follows:

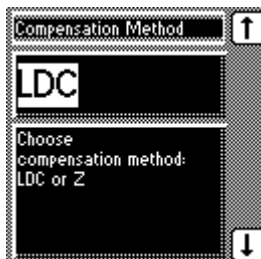

▶ **MENU** > **F3** Control parameter > **F4** Compensation method.

⇒ Compensation method.

⇒ Press **F1** or **F5** until the **LDC** option is displayed.

1. Press **←**.

2. The line drop compensation is selected.

The following sections describe how you can set the parameters for the ohmic and inductive voltage drop.

8.6.1.1 Setting the ohmic voltage drop U_r

You can use this parameter to set the ohmic voltage drop (ohmic resistance load).



If you do not want to use line drop compensation, you have to set the value 0.0 V.

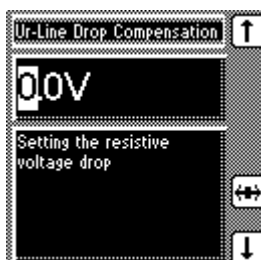

To set the ohmic voltage drop U_r , proceed as follows:

✓ Select the **LDC** compensation method.

1. **MENU** > **F3** Parameter > **F4** Compensation > Press **→** until the desired parameter is displayed.

⇒ U_r line drop compensation.

2. Press **F4** to highlight the position.

⇒ The desired position is highlighted and the value can be changed.

3. Press **F1** to increase the value or **F5** to reduce it.

4. Press **←**.

⇒ The ohmic voltage drop U_r is set.

8.6.1.2 Setting the inductive voltage drop U_x

You can use this parameter to set the inductive voltage drop (inductive resistance load). The compensation effect can be rotated by 180° in the display using a plus or minus sign.



If you do not want to use line drop compensation, you have to set the value 0.0 V.

To set the inductive voltage drop U_x , proceed as follows:

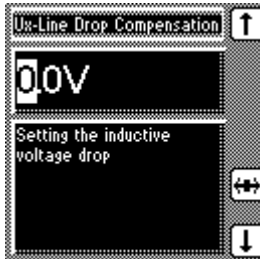

- ✓ Select the **LDC** compensation method.
- 1. **MENU** > **F3** Parameter > **F4** Compensation > Press **→** until the desired parameter is displayed.
⇒ U_x line drop compensation.
- 2. Press **F4** to highlight the position.
⇒ The desired position is highlighted and the value can be changed.
- 3. Press **F1** to increase the value or **F5** to reduce it.
- 4. Press **↵**.
⇒ The inductive voltage drop U_x is set.

8.6.2 Z compensation

To keep the voltage constant for the consumer, you can use Z compensation to activate a current-dependent increase in voltage. You can also define a limit value to avoid excess voltage on the transformer.

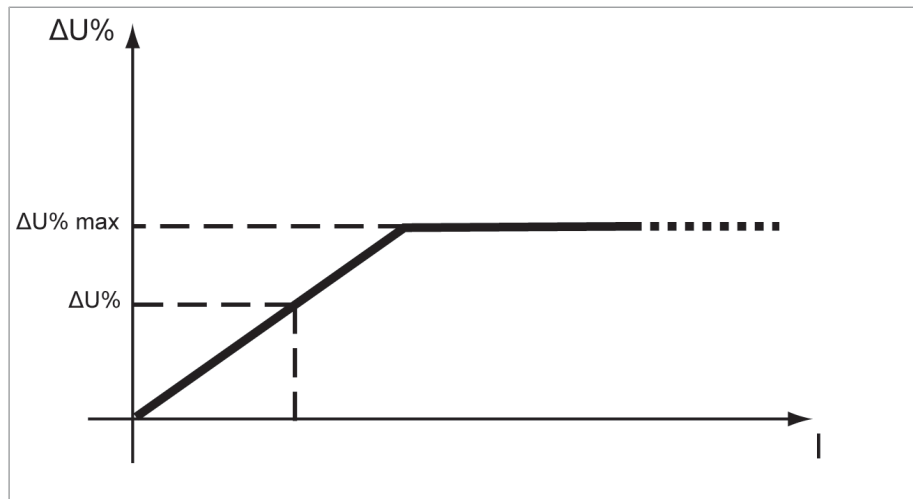

Figure 54: Z compensation

To use Z compensation, you need to calculate the increase in voltage (ΔU) taking the current into account. Use the following formula for this purpose:

$$\Delta U = 100 \cdot \frac{U_{Tr} - U_{Load}}{U_{Load}} \cdot \frac{I_N \cdot k_{CT}}{I}$$

ΔU	Voltage increase	I	Load current in A
U_{Tr}	Transformer voltage with current I	I_N	Nominal current of current-transformer connection in A (1 A; 5 A)
U_{Load}	Voltage on line end with current I and on-load tap-changer in same operating position	k_{CT}	Current transformer ratio



Sample calculation: $U_{Tr} = 100.1 \text{ V}$, $U_{Load} = 100.0 \text{ V}$, $I_N = 5 \text{ A}$ $k_{CT} = 200 \text{ A/5 A}$, $I = 100 \text{ A}$

Produces a voltage increase ΔU of 0.2%

The following sections describe how you can set the parameters you need for Z compensation.

Select Z compensation

To select the line drop compensation, proceed as follows:

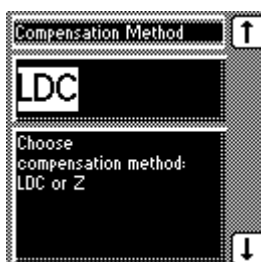

▶ **MENU** > **F3** Control parameter > **F4** Compensation method.
⇒ Compensation method.

⇒ Press **F1** or **F5** until the **Z** option is displayed.

1. Press **←**.

2. The Z compensation is selected.

The following sections describe how you can set the required parameters for Z compensation.

8.6.2.1 Setting Z compensation

This parameter sets the voltage increase ΔU previously calculated.



If you do not want to use Z compensation, you have to set the value 0.0 %.

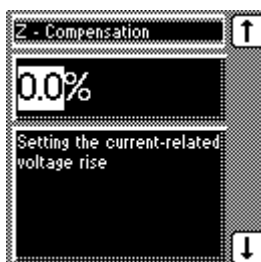

To set the current dependent voltage increase, proceed as follows:

✓ Select **Z** compensation.

1. **MENU** > **F3** Parameter > **F4** Compensation > Press **→** until the desired parameter is displayed.

⇒ Z compensation.

2. Press **F1** to increase the value or **F5** to reduce it.

3. Press **←**.

⇒ The current-dependent voltage increase is set.

8.6.2.2 Setting the Z compensation limit value

You can use this parameter to define the maximum permissible voltage increase to avoid excess voltage on the transformer.



If you do not want to use a limit value, you have to set the value 0.0 %.

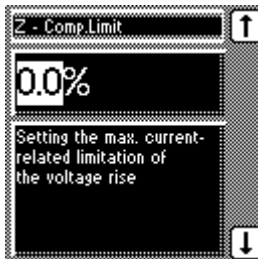

To set the limit value for the current-dependent voltage increase, proceed as follows:

- ✓ Select Z compensation.
 - ✓ Set the "Z compensation" parameter
1. **MENU** > **F3** Parameter > **F4** Compensation > Press **→** until the desired parameter is displayed.
⇒ Z comp. limit value.
 2. Press **F1** to increase the value or **F5** to reduce it.
 3. Press **↵**.
- ⇒ The limit value is set.

8.7 Transformer data

The transformation ratios and measuring set-up for the voltage and current transformers used in the system can be set with the following parameters. The device uses this information to calculate the corresponding measured values on the primary side of the current transformer (and therefore the transformer) from the recorded measured values. These are then displayed.

The following parameters are available for this purpose:

- Primary voltage
- Secondary voltage
- Primary current
- Secondary current (current transformer connection)
- Transformer circuit

The measured values displayed for the device are influenced by the settings for the above parameters. Note the table below.

Parameter set				Measured value display		
Primary voltage	Secondary voltage	Primary current	Transformer connection	Voltage (main screen)	Current (main screen)	Current (info screen)
-	Yes	-	-	Secondary voltage [V]	-	Secondary current [% of connection]
Yes	Yes	-	-	Primary voltage [kV]	-	Secondary current [% of connection]
Yes	Yes	Yes	-	Primary voltage [kV]	Primary current [A]	Secondary current [% of connection]

Parameter set				Measured value display		
Primary voltage	Secondary voltage	Primary current	Transformer connection	Voltage (main screen)	Current (main screen)	Current (info screen)
Yes	Yes	-	Yes	Primary voltage [kV]	-	Secondary current [A]
Yes	Yes	Yes	Yes	Primary voltage [kV]	Primary current [A]	Secondary current [A]

Table 15: Influence of transformer data on measured value display

8.7.1 Setting the primary transformer voltage

This parameter can be used to set the primary transformer voltage in kV. When you are setting the primary transformer voltage, the device shows the primary voltage rather than the secondary voltage in the main screen and you can also set the control parameters in kV.

If a setting of 0 kV is chosen, no primary transformer voltage is displayed.

To set the primary transformer voltage, proceed as follows:

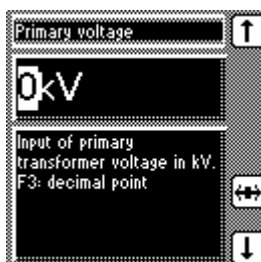

1. **MENU** > **F4** Configuration > **F2** Transformer data.
⇒ Primary voltage.
 2. Press **F3** to highlight the decimal place.
⇒ The decimal place is defined and the value can be changed.
 3. Press **F4** to highlight the position.
⇒ The desired position is highlighted and the value can be changed.
 4. Press **F1** to increase the value or **F5** to reduce it.
 5. Press **←**.
- ⇒ The primary transformer voltage is set.

8.7.2 Setting the secondary transformer voltage

This parameter can be used to set the secondary transformer voltage in V.

To set the secondary transformer voltage, proceed as follows:

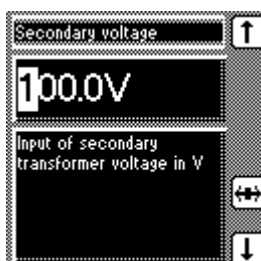

1. **MENU** > **F4** Configuration > **F2** Transformer data > Press **→** until the desired parameter is displayed.
⇒ Secondary voltage.
2. Press **F4** to highlight the position.
⇒ The desired position is highlighted and the value can be changed.
3. Press **F1** to increase the value or **F5** to reduce it.

4. Press .

⇒ The secondary transformer voltage is set.

8.7.3 Setting primary transformer current

This parameter can be used to set the primary transformer current.





- When you are setting the primary transformer current, the measured value is displayed in the main screen.
- If you set a value of 0, no measured value is displayed in the main screen.

Setting parameter		Current feed		Display	
Primary current	Secondary current	Power connection	Info screen Primary/secondary current	Main screen	
No parameterization	Unknown	1 A	100 %	0 A	
No parameterization	1 A	1 A	1 A	0 A	
50 A	Unknown	1 A	100 % (of primary current)	50 A (of primary current)	
50 A	1 A	1 A	1 A (of secondary current)	50 A (of primary current)	

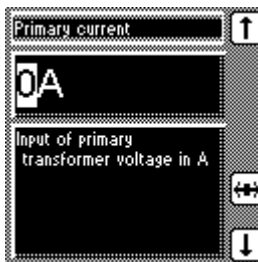
Table 16: Example of unit displayed: %/A

To set the primary transformer current, proceed as follows:





1. Press  >  Configuration >  Transformer data > Press  until the desired parameter is displayed.

⇒ Primary current.

2. Press  to highlight the position.

⇒ The desired position is highlighted and the value can be changed.

3. Press  to increase the value or  to reduce it.

4. Press .

⇒ The primary transformer current is set.

8.7.4 Setting the current transformer connection

This parameter can be used to set the current transformer connection. This setting is needed for the device to display the correct secondary current in the info screen.



If you select the "Unknown" option, the percentage of current (with reference to the current transformer connection used) is displayed in the info screen.

- 1 A
- 5 A

Proceed as follows to set the current-transformer connection:

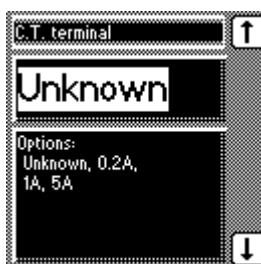

1. **MENU** > **F4** Configuration > **F2** Transformer data > Press **→** until the desired parameter is displayed.
⇒ Current-transformer connection
 2. Press **F1** or **F5** to select a current-transformer connection.
 3. Press **←**.
- ⇒ The current-transformer connection is set.

8.7.5 Setting the phase difference for the current transformer/voltage transformer

You can use this parameter to set the phase difference of the current transformer and voltage transformer. You can set the common transformer circuits as follows:

Tap-change operation	Setting	Measurement method	Phase difference
A	0 1PH	1 phase	0°
B	0 3PHN	3 phase	0°
C	0 3PH	3 phase	0°
D	90 3PH	3 phase	90°
E	30 3PH	3 phase	30°
F	-30 3PH	3 phase	-30°

Table 17: Set values for transformer circuit

Note the following sample circuits to select the correct transformer circuit.

Circuit A: 1-phase measurement in 1-phase grid

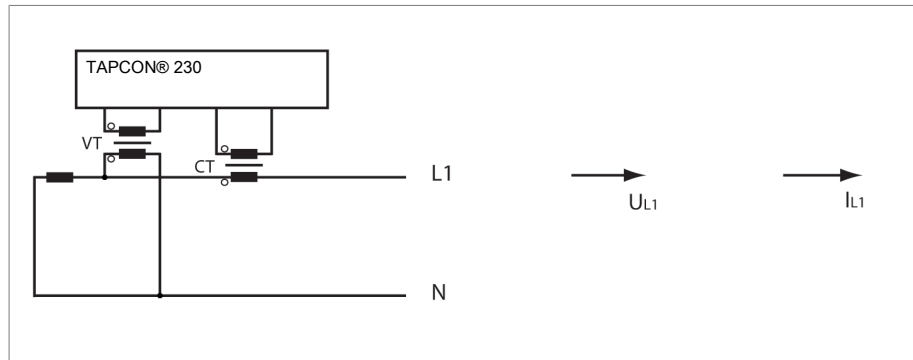

Figure 57: Phase difference 0 1PH

- The voltage transformer VT is connected to the outer conductor and neutral conductor.
- The current transformer CT is looped into the outer conductor.
- The voltage U_{L1} and current I_{L1} are in phase.
- The voltage drop on an outer conductor is determined by the current I_{L1} .

Circuit B: 1-phase measurement in 3-phase grid

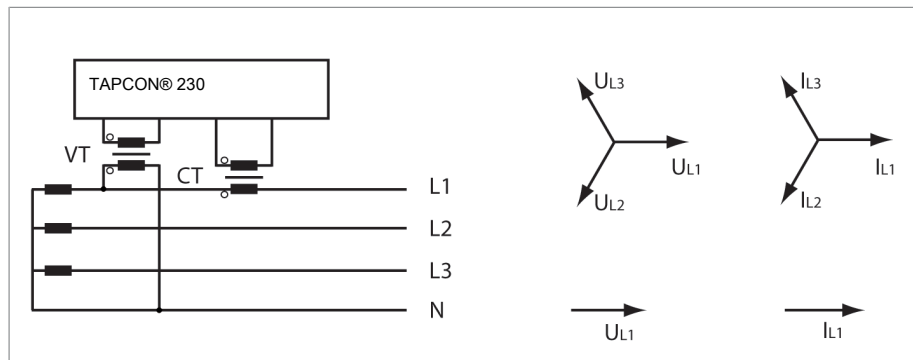

Figure 58: Phase difference 0 3PHN

- The voltage transformer VT is connected to the outer conductors L1 and neutral.
- The current transformer CT is looped into the outer conductor L1.
- The voltage U and current I are in phase.
- The voltage drop on an outer conductor is determined by the current I_{L1} .

Circuit C:

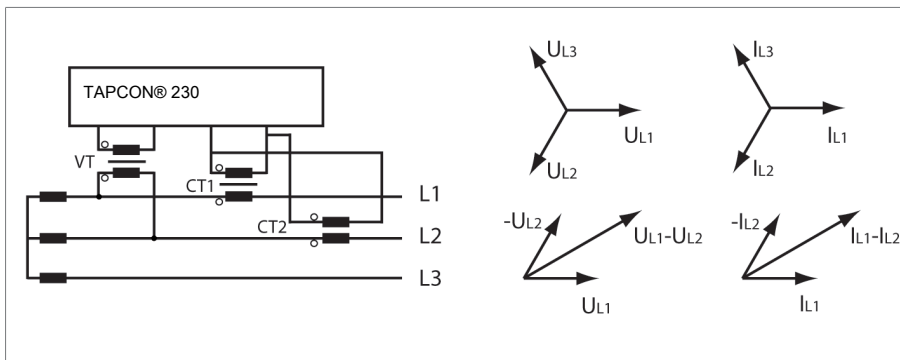

Figure 59: Phase difference 0 3PH

- The voltage transformer VT is connected to the outer conductors L1 and L2.
- The current transformer CT1 is looped into the outer conductor L1 and CT2 into the outer conductor L2.
- The current transformers CT1 and CT2 are connected crosswise in parallel (total current = $I_{L1} + I_{L2}$).
- The total current $I_{L1} + I_{L2}$ and voltage $U_{L1}-U_{L2}$ are in phase.
- The voltage drop on an outer conductor is determined by the current: $(I_{L1} + I_{L2}) / \sqrt{3}$.

Circuit D

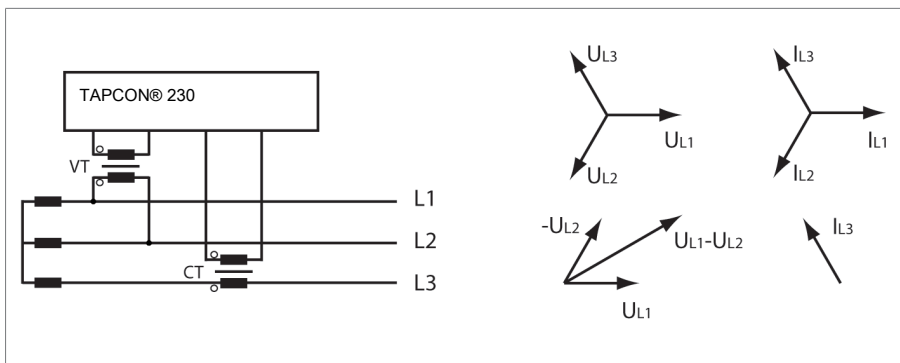

Figure 60: Phase difference 90 3PH

- The voltage transformer VT is connected to the outer conductors L1 and L2.
- The current transformer CT is looped into the outer conductor L3.
- The current I_{L3} is ahead of voltage $U_{L1}-U_{L2}$ by 90° .
- The voltage drop on an outer conductor is determined by the current I_{L3} .

Circuit E

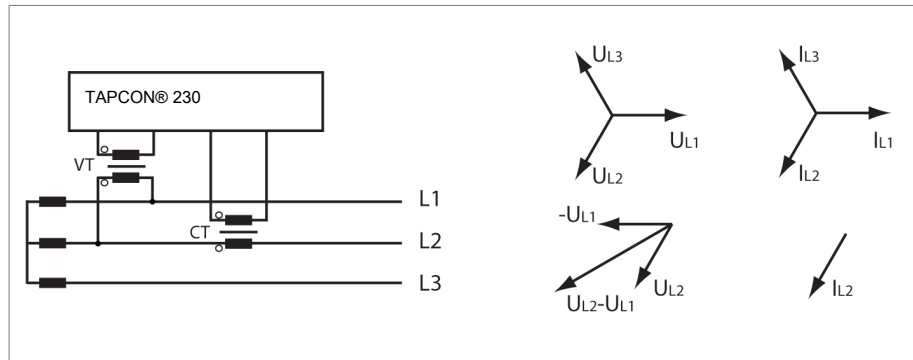

Figure 61: Phase difference 30 3PH

- The voltage transformer VT is connected to the outer conductors L1 and L2.
- The current transformer CT is looped into the outer conductor L2.
- The current I_{L2} is ahead of voltage $U_{L2}-U_{L1}$ by 30° .
- The voltage drop on an outer conductor is determined by the current I_{L2} .

Circuit F

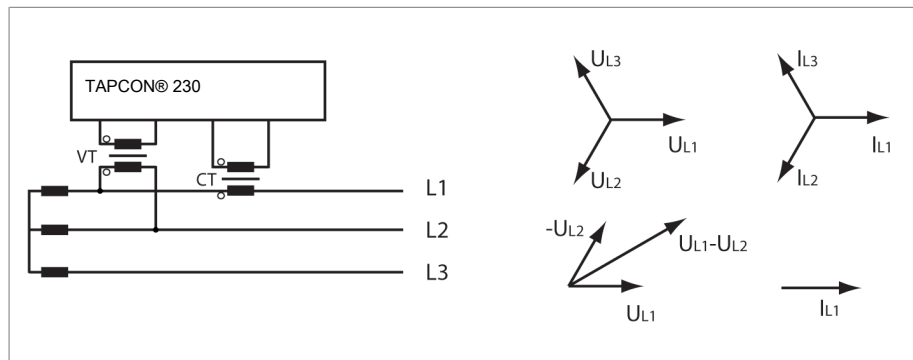
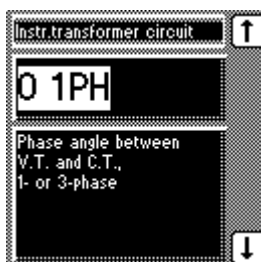

Figure 62: Phase difference -30 3PH

- The voltage transformer VT is connected to the outer conductors L1 and L2.
- The current transformer CT is looped into the outer conductor L1.
- The current I_{L1} lags behind $U_{L1}-U_{L2}$ by 30° . This corresponds to a phase shift of -30° .
- The voltage drop on an outer conductor is determined by the current I_{L1} .



To set the phase difference for the transformer circuit, proceed as follows:

1. **MENU** > **F4** Configuration > **F2** Transformer data > Press **→** until the desired parameter is displayed.
⇒ Transformer circuit.
 2. Press **F1** or **F5** to select the required phase difference.
 3. Press **←**.
- ⇒ The phase difference is set.

8.8 Parallel operation

In the **Parallel operation** menu item, you can set the parameters needed for parallel transformer operation. Parallel transformer operation is used to increase the throughput capacity or short-circuit capacity in one place.

Conditions for parallel operation

Compliance with the following general conditions is required for operating transformers in parallel:

- Identical rated voltages
- Transformer power ratio (< 3 : 1)
- Maximum deviation of short-circuit voltages (U_k) for transformers connected in parallel < 10%
- Same number of switching groups
- The same current-transformer connection has to be used for all devices running in parallel

You can control up to 16 transformers connected in parallel in one or 2 groups without detecting the system topology. Information is swapped between the voltage regulators operating in parallel using the CAN bus. Parallel operation is activated using one of 2 status inputs or the control system.

Parallel operation method

The device supports parallel operation following the methods described below:

- Parallel operation following the "Circulating reactive current minimization" principle
- Parallel operation following the "Tap synchronization" (master/follower) principle



You must select the same parallel operation method (circulating reactive current minimization or tap synchronization) for all voltage regulators operating in parallel. Otherwise you cannot operate the devices in parallel.

The following sections describe how you can set the parameters. Ensure that you have set the following parameters when activating parallel operation:

- CAN bus address

8.8.1 Assigning CAN bus address

You can use this parameter to assign a CAN bus address to the device. So that all devices can communicate using the CAN bus, each device requires a unique identifier. If the value is set to **0**, then no communication takes place.

To enter the CAN bus address, proceed as follows:



1. **MENU** > **F4** Configuration > **F4** Parallel operation > Press **→** until the desired parameter is displayed.
⇒ CAN address.
2. Press **F1** to increase the value or **F5** to reduce it.
3. Press **↵**.
⇒ The CAN bus address is saved.

8.8.2 Selecting parallel operation method

You can use this parameter to select a parallel operation method. Two different methods can be assigned to the device.

- Circulating reactive current minimization
- Tap synchronization (master/follower)



You must select the same parallel operation method for all voltage regulators operating in parallel.

The following sections describe how you can set the parameters for a parallel operation method.

8.8.2.1 Setting circulating reactive current method

When the **circulating reactive current** parallel operation method is selected, then parallel operation is carried out using the circulating reactive current minimization method. The circulating reactive current is calculated from the transformer currents and their phase angles. A voltage proportional to the circulating reactive current is added to the independently operating voltage regulators as a correction for the measurement voltage. This voltage correction can be reduced or increased using the circulating reactive current sensitivity setting.

The circulating reactive current method is suited to transformers connected in parallel with a similar nominal output and short-circuit voltage U_K and to vector groups with the same and different step voltages. This does not require any information about the tap position.

To set the **circulating reactive current** parallel operation method, proceed as follows:

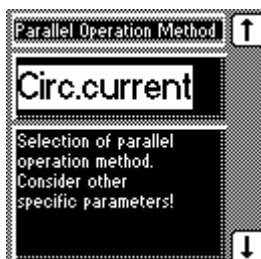

1. **MENU** > **F4** Configuration > **F4** Parallel operation > Press **→** until the desired parameter is displayed.
⇒ Parallel operation method
2. Press **F1** or **F5** until **circulating reactive current** appears in the display.
3. Press **↵**.

⇒ The parallel operation method is set.

When using the **circulating reactive current** parallel operation method, you have to set the parameters for the **circulating reactive current sensitivity** and **circulating reactive current blocking**.

Setting circulating reactive current sensitivity

The circulating reactive current sensitivity is a measure of its effect on the behavior of the voltage regulator. At a setting of 0 % no effect is present. With circulating reactive current relating to the rated current of the current transformer, if you set the value to 10 % for example, this would cause the voltage in the voltage regulator to be corrected by 10 %. This correction to the voltage can be increased or decreased with this setting to attain the optimum value.

As soon as you change the circulating reactive current sensitivity value, the value for the result changes in the help text in the display.

To set the circulating reactive current sensitivity, proceed as follows:

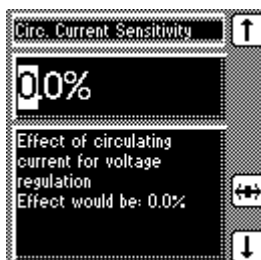

1. **MENU** > **F4** Configuration > **F4** Parallel operation > Press **→** until the desired parameter is displayed.
⇒ Circulating reactive current sensitivity
2. Press **F1** to increase the value or **F5** to reduce it.
3. If necessary, press **F3** to highlight the decimal place.
⇒ The decimal place is now highlighted and the value can be changed.
4. Press **↵**.

⇒ The circulating reactive current sensitivity is set.

Setting circulating reactive current blocking

You can use this parameter to set the limit value for the maximum permissible circulating reactive current. If, during parallel operation, the circulating reactive current exceeds the set limit value, then the following event is activated:

- Parallel operation error

All devices operating in parallel are blocked. Depending on the set delay time for the parallel operation error message, the signaling relay Parallel operation error is activated.

To set the blocking limit for the maximum permitted circulating reactive current, proceed as follows:

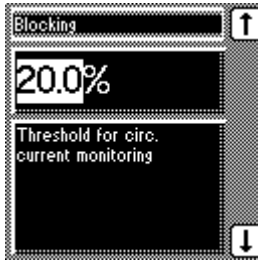

1. **MENU** > **F4** Configuration > **F4** Parallel operation > Press **→** until the desired parameter is displayed.

⇒ Circulating reactive current blocking

2. Press **F1** to increase the value or **F5** to reduce it.

3. Press **↵**.

⇒ The blocking limit for the maximum permitted circulating reactive current is set.

8.8.2.2 Setting tap synchronization

With the tap synchronization method, you need to designate one voltage regulator as the master and all others as followers. The master handles voltage regulation and transmits its latest tap positions to all followers via the CAN bus. The followers compare the tap position received with their own tap position. If the set permissible tap difference between the tap position received and their own position is exceeded, the followers switch to the tap position received from the master. This ensures that the transformers operating in parallel are always in the same tap position.

For the tap synchronization method, you can select the following options:

Option	Description
Master	The voltage regulator is designated as the master.
Follower	The voltage regulator is designated as the follower.
Sync.auto	Automatic assignment of master or follower. If no master is detected, the voltage regulator with the lowest CAN bus address is automatically designated as the master. All other voltage regulators are designated as followers.

Table 18: Tap synchronization method



In parallel operation, an individual CAN bus address must be assigned to each voltage regulator. Up to 16 CAN participants are supported.

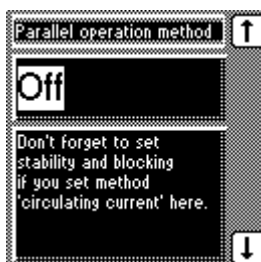

To set the tap synchronization method, proceed as follows:

1. **MENU** > **F4** Configuration > **F4** Parallel operation > Press **→** until the desired parameter is displayed.
⇒ Parallel operation method.
2. Press **F1** or **F5** until the desired parameter is displayed.
3. Press **↵**.
⇒ The tap synchronization method is set.

8.8.2.2.1 Setting the follower tapping direction

With this parameter, you can set how the follower behaves in the event of a raise or lower tap change.

As in "Tap synchronization (master/follower)" parallel operation the tap positions of the transformers which are running in parallel are compared, it is absolutely essential that these transformers have the same position designation. Ensure that all higher tap change operations or lower tap change operations produce the same voltage change in all transformers.

You can select the following options:

Option	Description
Standard dV>0 = tapping direction toward position 1	Follower sends a raise tap change command to increase the voltage. Follower sends a raise tap change command to increase the voltage.
Swapped dV>0 = tapping direction toward position n	Follower sends a lower tap change command to reduce the voltage. Follower sends a lower tap change command to reduce the voltage.
	Follower sends a raise tap change command to increase the voltage. Follower sends a lower tap change command to reduce the voltage.

Table 19: Device behavior



Please note whether the voltage regulator is defined as master or follower when setting the tapping direction. The tapping direction can only be swapped for a follower.

To select the tapping direction, proceed as follows:



1. **MENU** > **F4** Configuration > **F4** Parallel operation > Press **→** until the desired parameter is displayed.
⇒ Follower tapping direction.
2. Press **F1** or **F5** to select the required tapping direction.
3. Press **↵**.
⇒ The tapping direction is selected.

8.8.2.2 Setting the master/follower circulating reactive current blocking limit

This monitoring function is available in the "Master/follower tap synchronization" parallel operation mode in conjunction with a current measurement. The device is blocked as soon as the circulating reactive current reaches the blocking limit.

To activate/deactivate the circulating reactive current blocking limit, proceed as follows:

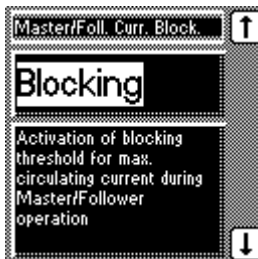

1. **MENU** > **F4** Configuration > **F4** Parallel operation > Press **→** until the desired parameter is displayed.
⇒ Master/follower current blocking.
2. Press **F1** or **F5** to activate blocking by selecting **Blocking** or to deactivate blocking by selecting **Off**.
3. Press **↵**.
⇒ The blocking is activated.

8.8.3 Assigning a parallel operation group

You can use this parameter to assign a transformer group to the device. You can create a total of 2 groups. The parallel operation group can be selected only if you have not programmed an allocation using a *GPI* control input.

The following groupings are possible:

Parameter	Function
None	Device not assigned to any parallel operation group
Group 1	Device assigned to parallel operation group 1
Group 2	Device assigned to parallel operation group 2
Group 1 and group 2	Device assigned to parallel operation groups 1 and 2

Table 20: Parallel operation groups



To assign the device to a parallel operation group, proceed as follows:

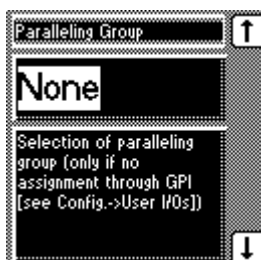

1. **MENU** > **F4** Configuration > **F4** Parallel operation > Press **→** until the desired parameter is displayed.
⇒ Parallel operation group.
 2. Press **F1** or **F5** until the desired setting is displayed.
 3. Press **←**.
- ⇒ The device is assigned to a parallel operation group.

8.8.4 Activating/deactivating blocking in simplex mode

With this parameter, you can configure if you want to prevent one single device handling regulation. This function is activated if only this one device is recognized in the parallel operation group using the CAN bus.

To activate/deactivate the **Simplex mode blocking** function, proceed as follows:

To activate/deactivate the simplex mode blocking function, proceed as follows:

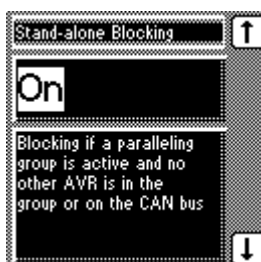

- ✓ Make sure that the device is assigned to a parallel operation group.
1. **MENU** > **F4** Configuration > **F4** Parallel operation > Press **→** until the desired parameter is displayed.
⇒ Simplex mode blocking.
 2. Press **F1** or **F5** to activate blocking by selecting **On** or to deactivate blocking by selecting **Off**.
 3. Press **←**.
- ⇒ Blocking in simplex mode is activated.

8.8.5 Setting delay time for parallel operation error messages

You can use this parameter to set the delay time for a parallel operation error message so that brief fault messages are not received if the motor-drive units involved in the parallel operation have different runtimes. Once the set delay time has elapsed, the event is issued at the output relay.

To set the delay time for the parallel operation error message, proceed as follows:

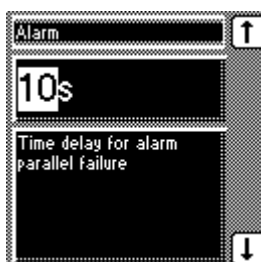

1. **MENU** > **F4** Configuration > **F4** Parallel operation > Press **→** until the desired parameter is displayed.
⇒ Error message.
 2. Press **F1** to increase the value or **F5** to reduce it.
 3. Press **←**.
- ⇒ The delay time for the parallel operation error message is set.

8.8.6 Configuring the maximum permitted tap difference

With this parameter, you can configure on the follower the maximum permitted tap difference between the follower and master.

In the **tap synchronization** parallel operation method, the tap positions of all transformers connected in parallel must be identical. Provided the tap difference is not greater than the maximum tap difference, the follower follows the master. If the tap difference is greater than the maximum tap position deviation, the follower and master block regulation immediately. After the set delay time for parallel operation error messages, the follower triggers the *Parallel operation error* message.

To set the maximum permitted tap difference, proceed as follows:



1. **MENU** > **F4** Configuration > **F4** Parallel operation > Press **→** until the desired parameter is displayed.
⇒ Max. tap difference.
 2. Press **F1** to increase the value or **F5** to reduce it.
 3. Press **↵**.
- ⇒ The maximum permitted tap difference is configured.

8.8.7 Activating/deactivating follower tapping without measured voltage

If the follower does not have its own voltage measurement or an existing voltage measurement has no function, this function can be used to define whether the device should block or should continue to carry out the master's control commands.

Setting	Function
On	Follower also taps without measured voltage
Off	Follower only taps with measured voltage

Table 21: Device behavior

To activate/deactivate this function, proceed as follows:



1. **MENU** > **F4** Configuration > **F4** Parallel operation > Press **→** until the desired parameter is displayed.
⇒ Follower tapping without U_{meas} .
 2. Press **F1** or **F5** to activate the function by selecting **On** or to deactivate the function by selecting **Off**.
 3. Press **↵**.
- ⇒ The function is set.

8.8.8 Activating/deactivating parallel operation

This parameter can be used to activate or deactivate parallel operation. When activating parallel operation, make sure you have configured the following parameters:

- CAN bus address
- Assigning a parallel operation group

To deactivate parallel operation, proceed as follows:

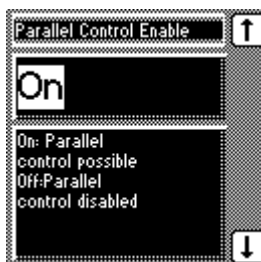

1. **MENU** > **F4** Configuration > **F4** Parallel operation.
⇒ Parallel operation activation
2. Press **F1** or **F5** to activate parallel operation by selecting **On** or deactivate parallel operation by selecting **Off**.
3. Press **←**.
⇒ Parallel operation is deactivated.

8.9 Tap position capture

The current tap position of the on-load- tap-changer is transferred from the motor-drive unit to the device. In accordance with your order, the tap position is transferred in one of the following ways:

- Digital signal
 - BCD
 - DUAL
 - GRAY
 - N/O contact series (external module)
- Analog signal
 - Injected current (0/4...20 mA)
 - Resistor contact series (200...2,000 ohms)

The following sections describe how you can set the required parameters for tap position capture. Additional parameters for the tap position limit values can be found in the section titled "Permitted tap positions" [► Section 8.5.6, Page 87].

8.9.1 Digital tap position capture

There is the option of transferring the tap position as a digital signal from the motor-drive unit to the device.

- BCD
- Binary code
- Gray code

To select the digital tap position capture, proceed as follows:



1. **MENU** > **F4** Configuration > **F5** Continue > **F5** Continue > **F3** Tap position
 ⇒ Tap pos. capture
 2. Press **F1** or **F5** to set the desired option (Binary/BCD/Gray).
 3. Press **←**.
- ⇒ The digital tap position capture is set.

No further settings are necessary.

8.9.2 Analog tap position capture

If the current tap position of the on-load tap-changer is captured using an analog signal, then the analog input (terminal strip X7) must be adapted to the signal of the tap position transmitter.



The analog input (terminal strip X7) can be used either for the input of the tap position or for setting the desired voltage level remotely.

You can use the following tap position transmitters:

PIO card (Terminal strip X7)	
Resistor contact series	200...2,000 ohms
Injected current	0/4...20 mA

Table 22: Analog tap position capture

Adjustment to the existing tap position transmitter must be carried out during commissioning.

To select an analog position capture, proceed as follows:



1. **MENU** > **F4** Configuration > **F5** Continue > **F5** Continue > **F3** Tap position
 ⇒ Tap pos. capture
 2. Press **F1** or **F5** to set the option you want.
 3. Press **←**.
- ⇒ The tap position capture is set.

No further settings are necessary.

8.9.2.1 Setting lower limit value

These parameters can be used to set the lower value for the tap position. To do this, you must set the lower value of the signal range and the linked lowest tap position.

You can undertake the settings for each input on the analog input card.



For example: To capture a tap position range of 1...19 via input 1 as 4...20 mA, you must set 20% for the "Analog value [%] Tap pos. min" parameter and 1.0 for the "Lowest tap position" parameter.

Setting lower limit value of input signal [%]

To configure the analog input, you must state the lower limit value of the input signal. Use the following settings depending on your analog signal:

Analog signal	Setting
Injected current: 0...20 mA	0 % (= 0 mA)
Injected current: 4...20 mA	20 % (= 4 mA)
Resistor contact series	always 20 %

Table 23: Parameter settings

To assign the minimum tap position to the analog value, proceed as follows:

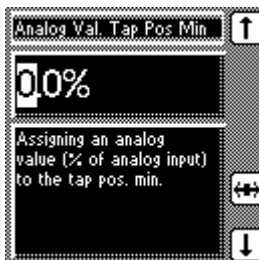

1. **MENU** > **F4** Configuration > **F5** Continue > **F5** Continue > **F3** Tap position > Press **→** until the desired parameter is displayed.
⇒ Analog Val. [%] Tap pos. min.
 2. Press **F4** to highlight a digit.
⇒ The desired position is highlighted and the value can be changed.
 3. Press **F1** to increase the value or **F5** to reduce it.
 4. Press **←**.
- ⇒ The analog value for the minimum tap positions is assigned.

Setting lower value of input signal

To configure the analog input, an absolute value must be assigned to the lower value of the applied signal.

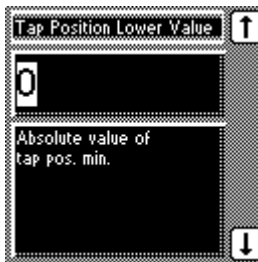

To set the lowest tap position, proceed as follows:

1. **MENU** > **F4** Configuration > **F5** Continue > **F5** Continue > **F3** Tap position > Press **→** until the desired parameter is displayed.
⇒ Lowest tap position
2. Press **F1** to increase the value or **F5** to reduce it.
3. Press **↵**.
⇒ The lowest tap position is set.

8.9.2.2 Setting upper limit value

These parameters can be used to set the upper value for the tap position. To do this, you must set the upper value of the signal range and linked highest tap position.

You can undertake the settings for each input on the analog input card.



For example: To capture a tap position range of 1...19 via input 1 as 4...20 mA, you must set 100% for the "Analog value [%] Tap pos. max" parameter and 19.0 for the "Highest tap position" parameter.

Setting upper limit value of input signal [%]

To configure the analog input, you must state the upper limit value for the input signal. Use the following settings depending on your analog signal:

Analog signal	Setting
Injected current: 0/4...20 mA	100 % (= 20 mA)
Resistor contact series	always 100 %

Table 24: Parameter settings

To assign the maximum tap position to the analog value, proceed as follows:

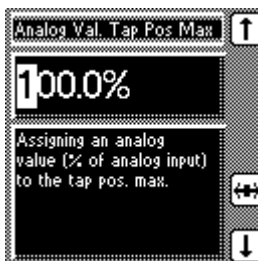

1. **MENU** > **F4** Configuration > **F5** Continue > **F5** Continue > **F3** Tap position > Press **→** until the desired parameter is displayed.
⇒ Analog Val. [%] Tap pos. max.
2. Press **F4** to highlight a digit.
⇒ The desired position is highlighted and the value can be changed.
3. Press **F1** to increase the value or **F5** to reduce it.
4. Press **↵**.
⇒ The analog value for the maximum tap position is assigned.

Setting upper value of input signal

To configure the analog input, an absolute value must be assigned to the upper value of the applied signal.

To set the highest tap position, proceed as follows:

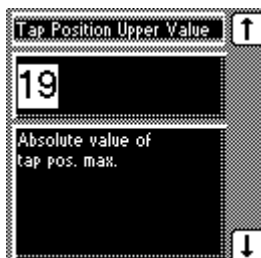

1. **MENU** > **F4** Configuration > **F5** Continue > **F5** Continue > **F3** Tap position > Press **→** until the desired parameter is displayed.

⇒ Highest tap position

2. Press **F1** to increase the value or **F5** to reduce it.

3. Press **←**.

⇒ The highest tap position is set.

8.10 Setting the desired voltage level remotely

The analog input can also be used to change the desired voltage value remotely. This requires the analog input (terminal strip X7) to be adapted to the voltage level transmitter signal.



The analog input (terminal strip X7) can be used either for the input of the tap position or for setting the desired voltage level remotely.

The following options are available for setting the desired voltage level remotely:

Analog setting of desired voltage level remotely

- Injected current: 0/4...20 mA
- Resistor contact series (200...2000 ohms)

8.10.1 Activate/deactivate setting the desired voltage level remotely.

You can use this parameter to activate or deactivate setting the desired voltage level remotely.

To activate/deactivate setting the desired voltage level remotely, proceed as follows:



1. **MENU** > **F4** Configuration > **F5** Continue > **F5** Continue > **F4** Set desired voltage level remotely > Press **→** until the desired parameter is displayed.

⇒ Set desired voltage level remotely.

2. Press **F1** or **F5** to activate (On) or deactivate (Off) setting the desired voltage level remotely.

3. Press .

⇒ Setting the desired voltage level remotely has been activated/deactivated.

8.10.2 Setting lower limit value for the desired value

To configure the analog input, state the analog value for the minimum desired value.

If you are using a desired value transmitter with a resistor contact series, select 20%.





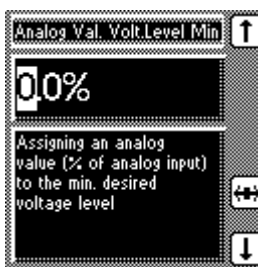

If you are using a desired value transmitter with injected current as the transmitter signal, either select 0% (for 0 mA) or 20% (for 4 mA).

Desired value	Current	Value
Minimum desired value 90 V	0 mA	0% (of analog input signal range)
	4 mA	20% (of analog input signal range)

Table 25: Examples of configuration for the analog input (desired value transmitter with injected current)

To set the analog value for the minimum desired value, proceed as follows:



1.  >  Configuration >  Continue >  Continue >  Remote Volt. Level Setting > Press  until the desired parameter appears.

⇒ Analog value % desired value min.

2. Press  to highlight a digit.

⇒ The desired position is highlighted and the value can be changed.

3. Press  to increase the value or  to reduce it.





4. Press .

⇒ The analog value for the minimum desired value is set.

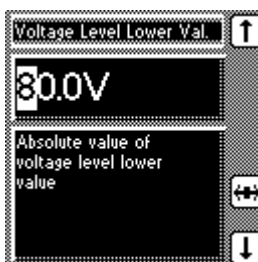
To configure the analog input, the minimum desired value must be assigned to the minimum analog value.

To set the minimum desired value, proceed as follows:



1.  >  Configuration >  Continue >  Continue >  Remote Volt. Level Setting > Press  until the desired parameter is displayed.

⇒ Minimum desired value

2. Press  to increase the value or  to reduce it.

3. Press .

⇒ The minimum desired value is set.

8.10.3 Setting upper limit value for the desired value

To configure the analog input, state the analog value for the maximum desired value.

If you are using a desired value transmitter with a resistor contact series, select 100%.





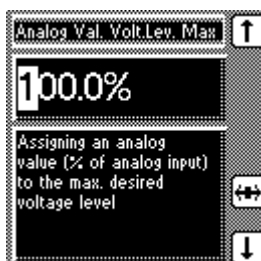

If you are using a desired value transmitter with injected current as the transmitter signal, select 100% (for 20 mA).

Desired value	Current	Value
Maximum desired value	20 mA	100% (of analog input signal range)

Table 26: Example of configuration for the analog input (desired value transmitter with injected current)



To set the analog value for the maximum desired value, proceed as follows:

1.  >  Configuration >  Continue >  Continue >  Remote Volt. Level Setting > Press  until the desired parameter is displayed.
⇒ Analog value % desired value max

2. Press  to highlight a digit.

⇒ The desired position is highlighted and the value can be changed.

3. Press  to increase the value or  to reduce it.





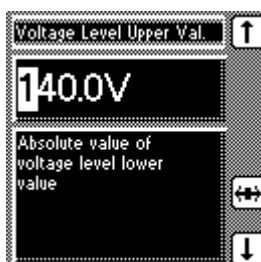

4. Press .

⇒ The analog value for the maximum desired value is set.

To configure the analog input, the maximum desired value must be assigned to the maximum analog value.

To set the maximum desired value, proceed as follows:



1.  >  Configuration >  Continue >  Continue >  Remote Volt. Level Setting > Press  until the desired parameter is displayed.
⇒ Maximum desired value

2. Press  to increase the value or  to reduce it.

3. Press .

⇒ The maximum desired value is set.

8.11 Configurable inputs and outputs

You can individually configure the digital inputs (GPI) and outputs (GPO).

The following digital inputs and outputs are available:

- 8 digital inputs (GPI1...8)
- 7 digital outputs (GPO1...7)

8.11.1 Linking inputs with functions

You can activate the inputs as follows :

- Statically using signal statuses
 - The input signal must be continually present (status: high level).
- Dynamically using pulses
 - A pulse (rising edge) is needed at the input. The input signal must change its status from "Low" to "High". If you are using a pulsed input, you can trigger the assigned function at the same time as the keys connected to the inputs also using the control system.



You can recognize pulsed inputs from the preceding "P:". The note "Warning: P = pulsed inputs" is displayed on the screen.

You can assign one of the following functions to each of the digital inputs (GPI 1...8):

Function	Description
Off	No function selected
Master/Foll.	Define master/follower mode. Signal on: Master mode active Signal off: Follower mode active.
Remote/Loc.	Define remote/local mode. Signal on: "Remote" operating mode active. Signal off: "Local" operating mode active.
Blocking	Block automatic regulation.
Quick Tap	Activating quick reset (deactivating delay time T1/T2)
MPS tripped	Input for <i>MPS tripped</i> feedback.
MD in progr.	Input for <i>MD in progr.</i> feedback.
DVL 2	Activate desired value level 2
DVL 3	Activate desired value level 3
Remote VL	Activate setting the desired voltage level remotely.



ParGroup1	Assign parallel operation group 1
ParGroup2	Assign parallel operation group 2
Blk U raise	Block tap-change operations (raise).
Blk U low.	Block tap-change operations (lower).
P: Par. on	Activate parallel operation.
P: S. mode	Deactivate parallel operation (independent).
P: Master	Define master parallel mode.
P: Follower	Define follower parallel mode.
P: Syn. aut.	Define "Automatic tap synchronization" parallel mode.
P: Cir. curr.	Define circulating reactive current mode.
P: DV 1	Activate desired value 1
P: DV 2	Activate desired value 2
P: DV 3	Activate desired value 3

Table 27: Functions for digital inputs (GPI 1...8)



If you assign the same functionality to two inputs, the device produces an event message [► Section 10, Page 135]. This also applies if you assign the same functionality via a static input and via a pulsed input.

Other examples of double assignment of functions are (n, m = 1...8):

- GPI n = master/follower and GPI m = P: Follower
- GPI n = master/follower and GPI m = P: Master

To assign a function to a digital input or to deactivate it, proceed as follows:



1. **MENU** > **F4** Configuration > **F5** Continue > **F3** User I/Os (press **...** for further GPIs).
⇒ GPI
2. Press **F1** or **F5** until the desired function is displayed.
3. Press **←**.
⇒ The function is set.

Functions can be assigned to all other GPIs as described above. You can select the GPIs as follows:

GPI	Press ...
GPI1 – X4:13	-
GPI2 – X4:14	1x
GPI3 – X4:15	2x
GPI4 – X4:16	3x

GPI	Press 
GPI5 – X4:17	4x
GPI6 – X4:18	5x
GPI7 – X6:1	6x
GPI8 – X6:2	7x

Table 28: Configurable GPIs

Also refer to

 Messages [ 135]

8.11.2 Linking outputs with functions

You can assign one of the following functions to the digital outputs (GPO 1...7):

Function	Description
Off	No function selected
Master	Assign master
Follower	Assign follower
ParState	Assign parallel operation status
ParError	Assign parallel operation error
Local/Rem.	Message: <i>Local control/remote control</i>
Undervoltage	Message: <i>Undervoltage blocking</i>
Overvoltage	Message: <i>Overvoltage blocking</i>
Undercurrent	Message: <i>Undercurrent blocking</i>
Overcurrent	Message: <i>Overcurrent blocking</i>
Desired value 1	Message: <i>Desired value 1</i>
Desired value 2	Message: <i>Desired value 2</i>
Desired value 3	Message: <i>Desired value 3</i>
MPS triggered	Message: <i>Motor protective switch was triggered</i>
Motor runtime >	Message: <i>Motor runtime exceeded</i>
Motor running	Message: <i>Motor running"</i>
Bandwidth <	Message: <i>Value fallen below bandwidth</i>
Bandwidth >	Message: <i>Bandwidth exceeded</i>
GPI 1	Message: <i>GPI 1 active</i>
GPI 2	Message: <i>GPI 2 active</i>



GPI 3	Message: <i>GPI 3 active</i>
GPI 4	Message: <i>GPI 4 active</i>
GPI 5	Message: <i>GPI 5 active</i>
GPI 6	Message: <i>GPI 6 active</i>
GPI 7	Message: <i>GPI 7 active</i>
GPI 8	Message: <i>GPI 8 active</i>
Event	Message : <i>Event active</i>
BCD +/-	Tap position in BCD code, prefix. The relay is triggered if the proceeding sign is negative.
BCD 1	Tap position in BCD code, position with value of 1.
BCD 2	Tap position in BCD code, position with value of 2.
BCD 4	Tap position in BCD code, position with value of 4.
BCD 8	Tap position in BCD code, position with value of 8.
BCD 10	Tap position in BCD code, position with value of 10.
BCD 20	Tap position in BCD code, position with value of 20.
BCD 40	Tap position in BCD code, position with value of 40.
Simplex mode	Message: <i>Parallel operation deactivated, independent</i>

Table 29: Functions for digital outputs (GPO 1...7)



If the device cannot determine the tap position, ? is displayed in the tap position display. The relays of all outputs with BCD functionality (NC) are switched off.

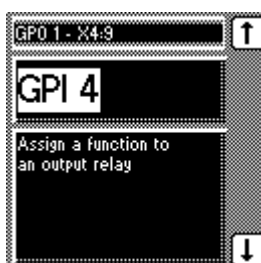

To assign a function to a digital output or to deactivate it, proceed as follows:

1. **MENU** > **F4** Configuration > **F5** Continue > **F3** User I/Os > Press **↔** until the desired parameter is displayed.
⇒ GPO.
 2. Press **F1** or **F5** until the desired function is displayed.
 3. Press **←**.
- ⇒ The function is set.

Functions can be assigned to all other GPOs as described above. You can select the GPOs as follows:

GPO	Press 
GPO1 – X4:9	8x
GPO2 – X4:12	9x
GPO3 – X5:9	10x
GPO4 – X5:12	11x
GPO5 – X5:18	12x
GPO6 – X5:21	13x
GPO7 – X5:24	14x

Table 30: Configurable GPOs

8.12 LED selection

You can use this parameter to assign functions to the free LEDs which light up when an event occurs. You can use labeling strips to label the LED.



Depending on your device configuration, the following parameters can be used by MR for special functions. In this case, these parameters are pre-assigned. You may not be able to view or freely assign these parameters.

Functions available for LEDs

An overview of all possible functions which you can assign to the LEDs is provided in the table below.

Functions available	Function description
Off	LED deactivated
GPI x	There is a signal at control input GPI x (e.g. GPI 1)
GPO x	The signaling relay at the GPO x (e.g. GPO 1) output has activated
Undercurrent	Undercurrent present
Par. error	Parallel operation error present
MPS triggered	Motor protective switch triggered
Blocking	Regulation is blocked
Circ. reactive current	Circulating reactive current parallel operation method is activated
Master	Device in parallel operation activated as master
Follower	Device in parallel operation activated as follower
Bandwidth <	Value is below bandwidth
Bandwidth >	Value is above bandwidth
Desired value 1	Desired value 1 activated
Desired value 2	Desired value 2 activated



Functions available	Function description
Desired value 3	Desired value 3 activated
Function monitoring	Function monitoring message active
Remote	Remote mode activated
Local	Local mode activated
Auto	Auto mode activated
Manual	Manual mode activated
Event	Event active

Table 31: Functions available for LEDs

Assigning function

To assign a function to an LED, proceed as follows:

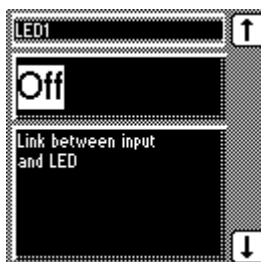

1. **MENU** > **F4** Configuration > **F5** Continue > **F4** LED selection > Press **...→** until the desired parameter is displayed.
 2. Press **F1** or **F5** to select the option you want.
 3. Press **↵**.
- ⇒ The function is assigned.

All additional LEDs can be assigned as described previously. The LEDs available can be called up as follows:

LED (parameter)	Characteristics	Press ...→
LED 1	Single-colored	-
LED 2	Single-colored	1x
LED 3 yellow	Two-colored	2x
LED 3 green	Two-colored	3x
LED 4 rot	Two-colored	4x
LED 4 yellow	Two-colored	5x

Table 32: Configurable LEDs

8.13 Information about device

8.13.1 Displaying info screen

The info screen displays the following information:

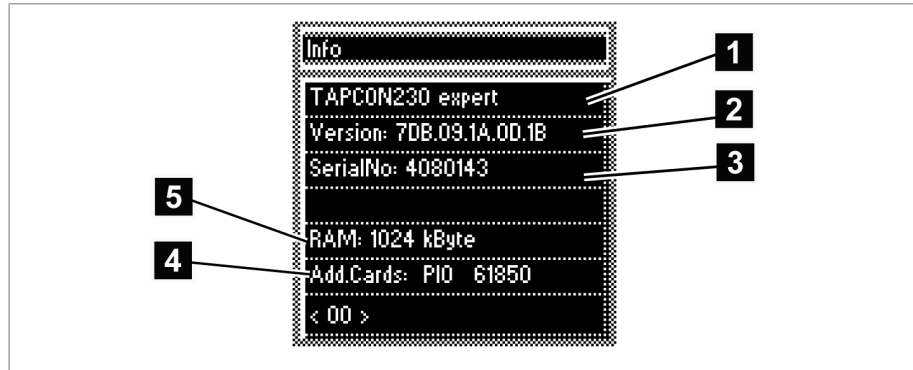

Figure 68: Info screen

1 Type designation	4 Additional cards
2 Software version	5 RAM memory
3 Serial number	

To display the info screen, proceed as follows:

▶ **MENU** > **F5** Info.

⇒ Info.

8.13.2 Displaying measured values

The current measured values are shown in this display. The values on the right in rows **1**, **2** and **4** are only displayed if the transformer data [▶ Section 8.7, Page 94] has been entered previously. In row **4**, the value actually measured can be seen on the left and the value converted to the transformer circuit is on the right.

The following measured values can be displayed:

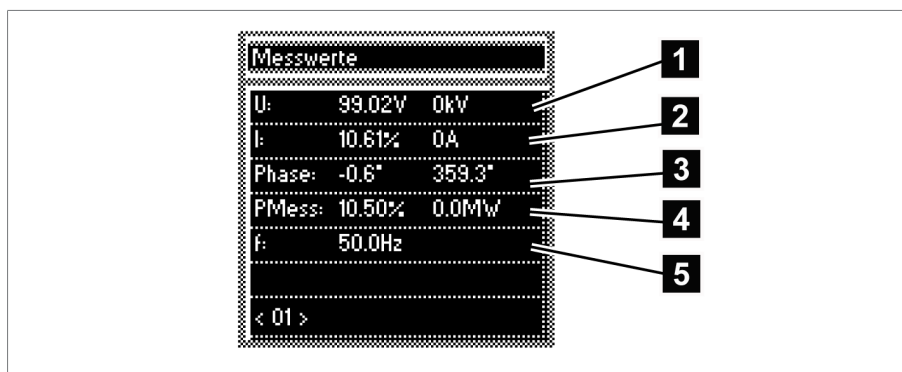

Figure 69: Measured values

1 Voltage U in V or kV	4 Measurement performance PMeas in % or MW
2 Current I in A or kA	5 Frequency f in Hz
3 Phase angle from U to I in degrees	

To display the measured values, proceed as follows:

- ▶ **MENU** > **F5** Info > Press **→** until the desired display appears.
- ⇒ Measured values.

8.13.3 Display calculated values

Calculated values are shown on this screen . The following values can be displayed:

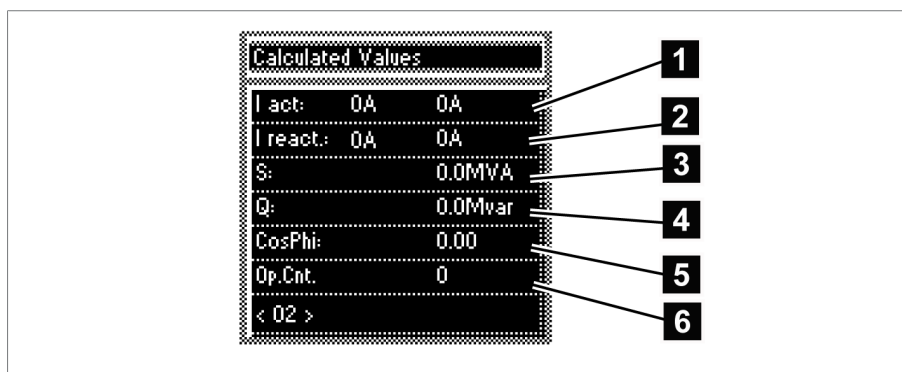

Figure 70: Calculated values

1 I active (active share) in A	4 Reactive power Q in Mvar
2 I reactive (reactive share) in A	5 Power factor cos ϕ
3 Apparent power S in MVA	6 Operation counter

The values in the rows on the right are only displayed if the transformer data has been entered previously.

To display the calculated values, proceed as follows:

▶ **MENU** > **F5** Info > Press **→** until the desired display appears.

⇒ Calculated values

8.13.4 Carrying out LED test

You can check whether the LEDs are functioning properly. To do this, press the relevant function key to illuminate an LED:

Key	LED no.
F1 ... F5	LED 1...LED 5
F1 + F5 ... F4 + F5	LED 6...LED 9
←	All LEDs

Table 33: Arrangement of keys for the LED test



This function will only test the functional reliability of the respective LED. The function of the device linked to the LED is not tested.

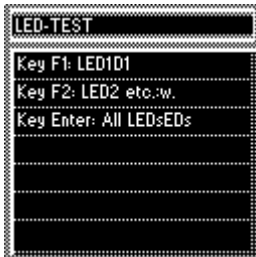

To carry out the LED test, proceed as follows:

1. **MENU** > **F5** Info > Press **→** until the desired display appears.

⇒ LED test.

2. To carry out the function test, press the function key for the LED you want to test.

8.13.5 Displaying status of the MIO card

The status of the digital inputs and outputs are shown in this display.



Digital inputs

The status of the optocoupler inputs is shown in the "MIO card digital inputs" display. As soon as a continuous signal is present at the input, status **1** is displayed. **0** indicates no signal at the input.

MIO-Card Digital Inputs	
X4-13 0	X4-14 0
X4-15 0	X4-16 0
X4-17 0	X4-18 0
X4-21 0	X4-22 0
X4-23 0	X4-24 0

Proceed as follows to display the status:

- ▶ **MENU** > **F5** Info > Press **→** until the desired display appears.
- ⇒ MIO card digital inputs

Digital outputs

The status of the relays is shown in the "MIO card digital outputs" display. As soon as a relay has activated, status **1** is displayed. If status **0** is displayed, the relay has not activated.

MIO-Card Digital Outputs	
X3-3 0	X3-6 0
X3-9 0	X3-12 1
X4-3 0	X4-6 0
X4-9 0	X4-12 0

Proceed as follows to display the status:

- ▶ **MENU** > **F5** Info > Press **→** until the desired display appears.
- ⇒ MIO card digital outputs

8.13.6 Displaying status of the PIO card

Information about the digital inputs, outputs and the analog input is shown in this display.

Digital inputs

The statuses of the optocoupler inputs are shown in this display. As soon as a continuous signal is present at the input, status **1** is displayed. **0** indicates no signal at the input.

PIO-Card Digital Inputs	
X6-1 0	X6-2 0
X6-10 0	X6-11 0
X6-12 0	X6-13 0
X6-14 0	X6-15 0
X6-16 0	

To display the "PIO card digital inputs" screen, proceed as follows:

- ▶ **MENU** > **F5** Info > Press **→** until the desired display appears.
- ⇒ PIO card digital inputs

Digital outputs

The statuses of the relays are shown in this display. As soon as a relay has activated, status **1** is displayed. If status **0** is displayed, the relay hasn't activated.

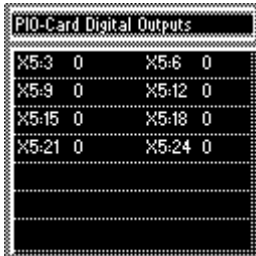

To display the "PIO card digital outputs" screen, proceed as follows:

▶ **MENU** > **F5** Info > Press **→** until the desired display appears.

⇒ PIO card digital outputs

Analog input

Information relating to the analog input is shown in this display.



If *Not yet calibrated!* is displayed, you need to calibrate [▶ Section 7.3, Page 49] the analog input in order to use it to capture the tap position or set the desired voltage level remotely.

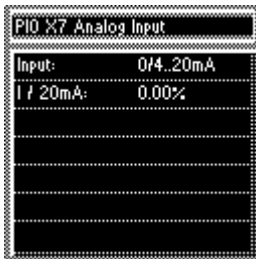

To display information about the analog input, proceed as follows:

▶ **MENU** > **F5** Info > Press **→** until the desired display appears.

⇒ PIO X7 analog input

8.13.7 Displaying parallel operation

This display indicates the control number for parallel operation (= CAN bus address) and the number of devices which are currently operating in parallel.

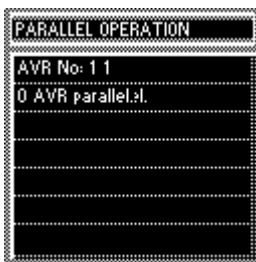

To display data for parallel operation, proceed as follows:

▶ **MENU** > **F5** Info > Press **→** until the desired display appears.

⇒ Parallel operation.



8.13.8 Displaying data on CAN bus

The CAN bus data of the connected devices is shown in this display.

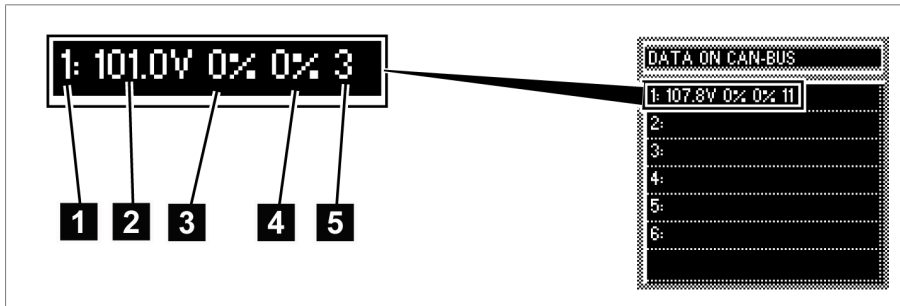

Figure 71: CAN bus data

1	CAN bus address of device	4	Reactive current in %
2	Actual voltage (U_{Act}) in V	5	Tap position
3	Active current in %		

To display information about data on the CAN bus, proceed as follows:

▶ **MENU** > **F5** Info > Press **→** until the desired display appears.

⇒ Data on CAN bus.

8.13.9 Peak memory

This display shows the minimum and maximum voltage measured since the last reset and the minimum and maximum on-load tap-changer tap positions. All values recorded are stored with a time and date.



The minimum and maximum values continue to be stored in an internal fixed value memory even in the event of power failure.

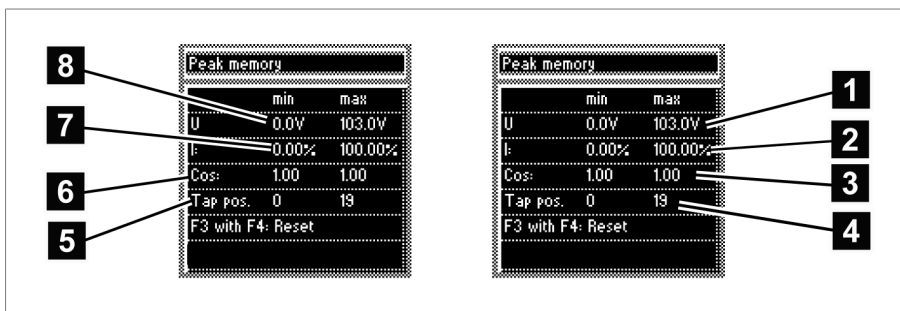

Figure 72: Peak memory

1	Maximum measured voltage U	5	Minimum on-load tap-changer tap position
2	Maximum measured current I	6	Minimum measured power factor $\cos \varphi$

3 Maximum measured power factor cos φ	7 Minimum measured current I
4 Maximum on-load tap-changer tap position	8 Minimum measured voltage U

To display data stored in the peak memory, proceed as follows:

▶ **MENU** > **F5** Info > Press **→** until the desired display appears.

⇒ Peak memory.

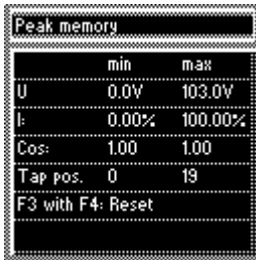

Resetting peak memory

To reset the peak memory, proceed as follows:

1. **MENU** > **F5** Info > Press **→** until the desired display appears.

⇒ Peak memory.

2. Press **F3** and **F4** at the same time.

⇒ The peak memory is reset.

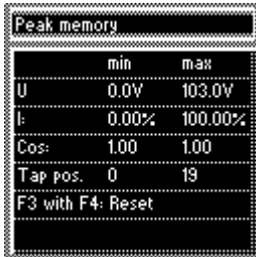

8.13.10 Resetting parameters

With this display you can reset your settings to the factory settings . It also shows whether all parameters are saved correctly.



Resetting the parameters to the factory settings permanently deletes your settings.

To reset all parameters, proceed as follows:

1. **MENU** > **F5** Info > Press **→** until the desired display appears.

⇒ Default parameter

2. Press **F3** and **←** at the same time.

⇒ "Default parameter active" is displayed.

⇒ All parameters have been reset to the factory settings.

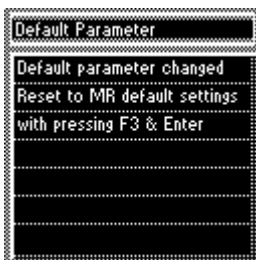



8.13.11 Displaying memory overview

The memory overview can be used to display various database entries with the relevant number of data records. The information is not relevant for operation. It is only needed for service checks. The following information is displayed:

- Parameter file
- Event data bits
- Flash file
- Events

To display the database entries, proceed as follows:



1. **MENU** > **F5** Info > Press **→** until the desired display appears.
⇒ Memory overview
2. Press **F1** or **F5** to select an entry.
⇒ The relevant number of data records is displayed.

8.13.12 Displaying event overview

This display can be used to display the number of current red and yellow events. The events are marked as follows:

Yellow	Corresponds to an advance warning or status information.
Red	Automatic regulation can block.

Table 34: Coding of events

A list with all events can be found in the Messages [► Section 10, Page 135] section.

To view the event overview, proceed as follows:



- **MENU** > **F5** Info > Press **→** until the desired display appears.
⇒ Event overview.

9 Fault elimination

This chapter describes how to rectify simple operating faults.

9.1 No regulation in AUTO mode



Characteristics/detail	Cause	Remedy
Device control commands have no effect.	LOCAL/REMOTE switch in motor-drive unit switched to LOCAL.	Check operating mode. Correct if necessary.
RAISE/LOWER LEDs light up periodically	No connection	Check wiring as per connection diagram.
Blocking	Reverse power lock active.	Check parameters. Correct if necessary.
	Negative power flow	Check current transformer polarity.
	Function assigned to several GPIs.	Check parameterization of GPIs. Correct if necessary.
	One of the GPIs is parameterized with "Blocking" and has an appropriate input signal.	Check parameterization and status in "Info" menu. Correct if necessary.
	NORMset active	Carry out manual tap-change operation with  or  keys.
	Undercurrent blocking active	Check parameters. Correct if necessary.
Blocking U< LED illuminated	Undervoltage blocking active	Check parameters. Correct if necessary.
Blocking U> LED illuminated	Overvoltage blocking active	Check parameters. Correct if necessary.
Blocking I> LED illuminated	Overcurrent blocking active	Check parameters. Correct if necessary.
Bandwidth set too high	-	Determine the recommended bandwidth

Table 35: No regulation in AUTO mode

9.2 Unexplained tap change

Characteristics/detail	Cause	Remedy
Compensation activated	Setting: <ul style="list-style-type: none"> ▪ Line drop compensation ▪ Z compensation 	Check parameters. Correct if necessary.

Table 36: Unexplained tap change



9.3 Man-machine interface

Characteristics/detail	Cause	Remedy
Keys <ul style="list-style-type: none"> MANUAL/AUTO operating mode cannot be changed 	REMOTE operating mode active and LED in key illuminated.	Press to activate LOCAL mode.
Keys <ul style="list-style-type: none"> LEDs in keys and not illuminated. 	Parameter error	Reset parameters to factory settings.
Display <ul style="list-style-type: none"> No display. 	Contrast incorrectly set.	Set contrast [▶ Section 7.1, Page 47].
	Voltage supply interrupted.	Check voltage supply.
	Fuse faulty.	Contact Maschinenfabrik Reinhausen.
LEDs <ul style="list-style-type: none"> Freely configurable LED lights up 	Customized LED parameterization.	Check parameters.
LEDs <ul style="list-style-type: none"> LED flashing 	Input signal not constant.	Check input signal.
COM1 <ul style="list-style-type: none"> Cannot be connected to PC using TAPCON®-trol. 	Different baud rates set.	Check baud rate set on device and PC.

Table 37: Man-machine interface

9.4 Incorrect measured values

Characteristics/detail	Cause	Remedy
Measured voltage <ul style="list-style-type: none"> No measured value. 	Connection has no contact in the plug terminal.	Check wiring and plug terminal.
	Insulation trapped	
	Wire not inserted far enough.	
	Circuit breaker tripped.	Check fuse.
Measured voltage <ul style="list-style-type: none"> Measured value too low. 	Voltage drop on measuring lead.	Check measured voltage at plug terminal X2:1/ X2:2.
Measured voltage <ul style="list-style-type: none"> Measured value fluctuates. 	Possible sources of fault: <ul style="list-style-type: none"> Leads laid in parallel. Tap-change operations. 	Check measured voltage at plug terminal X2:1/ X2:2.
		Increase distance from source of interference.
		Install filter if necessary.
Measured current <ul style="list-style-type: none"> No measured value. 	Line to current transformer interrupted.	Check wiring.
	Short-circuiting jumper in current transformer not removed.	Remove short-circuiting jumper.



Characteristics/detail	Cause	Remedy
Measured current <ul style="list-style-type: none"> Measured value too high. Measured value too low. 	Transmission ratio not correctly parameterized.	Correct parameterization.
	Incorrect input connected.	Remove short-circuiting jumper.
Phase angle <ul style="list-style-type: none"> U/I. 	Fault in external transformer circuit.	Check transformer circuit.
	Transformer circuit incorrectly parameterized.	Compare with system connection diagram.
		Correct parameters.
		Compare measurement values on info screen.
		Transpose current transformer connection.
		Check polarity of transformer circuit.
Correct if necessary.		
	Check circuit.	
	Correct if necessary.	
	Check measurement points.	
	Correct if necessary.	

Table 38: Incorrect measured values

9.5 Parallel operation faults

Characteristics/detail	Cause	Remedy
Parallel operation cannot be activated. <ul style="list-style-type: none"> LED not lit up. 	"Parallel operation method" parameter deactivated.	Set parallel operation method parameters.
	CAN bus address of device set to "0".	Set CAN bus address (anything but 0).
Problem with CAN bus. <ul style="list-style-type: none"> Device not listed. 	Device incorrectly connected (plug twisted, offset).	Check connections. Connect as shown in connection diagram.
	Devices have the same CAN bus addresses.	Set different CAN bus addresses.

Table 39: Parallel operation faults

9.6 Tap position capture incorrect

Characteristics/detail	Cause	Remedy
Step display incorrect. <ul style="list-style-type: none"> Plus or minus sign incorrect 	Incorrect wiring.	Check wiring. Connect as shown in connection diagram.
	Minimum value of analog input signal not correctly parameterized.	Check parameters. Set "Analog Val. [%] Tap Pos. Min." parameter.



Characteristics/detail	Cause	Remedy
Step display incorrect. ▪ Display fluctuates.	Interference.	Shield the line. Increase distance from source of interference. Lay interference lines separately. Route signal in separate lines (filter, shielded lines).
No step display. ▪ "-" is displayed.	No measurement signal. No L- for digital input.	Connect signal as shown in connection diagram. Check wiring. Display MIO card status. Display PIO card status. Connect as shown in connection diagram.
No step display. ▪ "?" is displayed.	Bit combination (code) impermissible. "Motor running" signal present.	Check wiring. MIO card status. Display PIO card status. Check signal sequence Display MIO card status. Display PIO card status.

Table 40: Tap position capture

9.7 Customized GPIs/GPOs

Characteristics/detail	Cause	Remedy
Function expected from the factory setting does not take place	Parameterization has been overwritten manually or via TAPCON®-trol.	Check active parameters
Signal discontinuous.	Intermittent DC voltage.	Check source of DC voltage. Check signal transmitter. Check wiring.
No signal Info screens "Bandwidth!", "Delay time T1", "Control response T1", "Delay time T2" display 0.	Supply voltage too low	Reset parameters to factory settings.

Table 41: Fault elimination: GPIs and GPOs

9.8 General faults

Characteristics/detail	Cause	Remedy
No function ▪ <i>Operating status</i> LED does not illuminate	No power supply Fuse tripped	Check the power supply Contact Maschinenfabrik Reinhausen GmbH



Characteristics/detail	Cause	Remedy
Relays chatter	Supply voltage too low	Check the supply voltage
	High EMC load	Use shielded cables or external filters
	Poor grounding	Check protective ground

Table 42: General faults

9.9 Other faults

If you cannot resolve a problem, please contact Maschinenfabrik Reinhausen. Please have the following data on hand:

- Serial number
 - Name plate (Outer right side when viewed from the front [► Section 4.5.1, Page 20])
 - Info screen (MENU > F5 Info)

Please provide answers to the following questions:

- Has a firmware update been carried out?
- Has there previously been a problem with this device?
- Have you previously contacted Maschinenfabrik Reinhausen about this issue? If yes, then who was the contact?



10 Messages

No.	Event (yellow/red)	Event message	Remark
3	Red	Undervoltage	Message is displayed in the event of undervoltage. Set the Undervoltage U< [▶ Section , Page 80] parameter.
4	Red	Overvoltage	Message is displayed in the event of overvoltage. Set the Overvoltage U> [▶ Section , Page 83] parameter.
5	Red	Overcurrent	Message is displayed in the event of overcurrent. Set the Overcurrent I> [▶ Section , Page 85] parameter.
6	Red	Parallel operation error: Different parallel operation methods	Message is displayed if different parallel operation methods are set for 2 or more devices in the same parallel operation group. Set the Parallel operation method parameter.
7	Yellow	Motor protection device	Triggered by the motor protective switch input.
9	Yellow	Undercurrent	Message is displayed in the event of undercurrent. Set the Undercurrent I< [▶ Section , Page 86] parameter.
11	Red	Error when setting user inputs (duplicate assignment)	At least 2 user inputs are parameterized to the same function. Message is displayed after the 2nd parameter has been confirmed with  .
12	Yellow	Function monitoring (voltage not adjusted within set time)	Message is displayed if the voltage has not been adjusted within the set time (presetting: 15 minutes).
13	Yellow	Motor-drive unit runtime monitoring	Message is displayed if the set motor runtime is exceeded. Setting motor runtime monitoring [▶ Section 8.2.8, Page 66] parameters.
14	Red	Analog input value too high. Check your connection to terminal X7!	Message is displayed when the maximum permissible current of 20 mA is exceeded for connection X7.
15	Yellow	Negative analog input value Check your connection to terminal X7!	Message is displayed in the event of reverse polarity or if X7 connection is incorrectly connected.
16	Red	Parameter reloaded! Confirm with F3 & Enter	Message is displayed if the current set of parameters is corrupt or damaged and the system has therefore switched to the standard set of parameters.
17	Yellow	Check sliding contact.	Message is displayed if the resistor contact series is incorrectly connected or has a loose contact.
18	Yellow	No other CAN bus participants present	Message is displayed if parallel operation has been set but there is not a device in the same parallel operation group or the CAN bus is actually interrupted.
19	Red	Parallel operation error: Circulating reactive current blocking limit exceeded	Message is displayed if the parallel operation method is using circulating reactive current or master/follower and the blocking limit is activated. The circulating reactive current limit must also be exceeded.
20	Red	Parallel operation error: Invalid tap position present on parallel regulators	Message is displayed if a tap position on a parallel voltage regulator is invalid.



No.	Event (yellow/red)	Event message	Remark
21	Red	Parallel operation error: Tap difference to follower	Message is displayed on master if a follower still has the same tap position as the master after the set delay time. Set delay time T1. [► Section 8.4.4, Page 77] parameter.
22	Red	Parallel operation error: Permitted tap difference to master exceeded	Message is displayed on follower if a follower is still not within the permitted tap difference to the master's tap position after the set delay time.
23	Red	Parallel operation error: Number of masters on CAN bus >1	Message is displayed if several regulators in a parallel operation group have been set as the master.
24	Red	Parallel operation error: No master present or master tap position invalid	Message is displayed if no device has been set as the master or the master is reporting an invalid tap position.
25	Red	Parallel operation error: CAN bus address selected already in use	Message is displayed if the set CAN address is already in use.
26	Red	Parallel operation error: Circulating reactive current invalid	Message is displayed if the current measurement for at least one device is invalid and the circulating reactive current to be calculated is therefore invalid when the "Circulating reactive current" parallel operation method is active.
27	Red	Parallel operation error: Blocking initiated by other regulator	Message is displayed if blocking is initiated by another device.
28	Red	Parallel operation error: No other regulators in parallel operation group	Message is displayed if there are no more devices in the parallel operation group.
30	Red	Blocking: Signal at blocking user input	Message is displayed if there is a signal at the set "Automatic regulation blocked" (blocking) user input.
31	Red	Blocking: Negative active power	Message is displayed if the active power is negative and blocking is activated for negative active power.
32	Red	Blocking: User input Lower tap-change blocking	Message is displayed if there is a signal at the set "Raise pulse blocked" (Bik U raise) user input.
33	Red	Blocking: Signal at block raise user input	Message is displayed if there is a signal at the set "Lower pulse blocked" user input.
34	Red	Blocking: Lower blocked because tap position limit reached or exceeded	Message is displayed if lower is blocked because the corresponding tap position limit has been reached or exceeded.
35	Red	Blocking: Raise blocked because tap position limit reached or exceeded	Message is displayed if raise is blocked because the corresponding tap position limit has been reached or exceeded.
36	Yellow	Tap position limit reached or exceeded	Message is displayed if the set tap position limit has been reached or exceeded.
37	Yellow	Negative active power	Message is displayed if the active power is negative.
38	Yellow	No connection to communication interface card	Message is displayed if communication to the communication interface card <i>IEC 61850 card</i> is not possible.

Table 43: Event message



11 Disposal

Observe the national requirements applicable in the country of use.



12 Overview of parameters

This section contains an overview of the relevant menus and parameters. The availability of individual parameters varies depending on your device function.

Parameter	Setting range	Factory setting	Current setting
NORMset			
Normset activation	On/Off	Off	
Desired value 1	49 to 140 V	100 V	
Primary voltage	0...9999 kV	0 kV	
Secondary voltage	57 to 123 V	100 V	
Control parameters > Voltage regulation			
Desired value 1	49 to 140 V	100.0 V	
Desired value 2	49 to 140 V	100.0 V	
Desired value 3	49 to 140 V	100.0 %	
Desired value selection	Desired value 1; Desired value 2; Desired value 3	Desired value 1	
Bandwidth	0.5...9 %	2.00 %	
Delay time T1	0...600 s	40 s	
Control response T1	T1 linear/T1 integral	T1 linear	
Activation T2	T2 on/T2 off	T2 off	
Delay time T2	1...10 s	10.0 s	
Control parameters > Limit values			
Undervoltage U< [%]	60...100 %	90 %	
Delay time U<	0...20 s	10.0 s	
Undervolt. blocking U<	On/Off	On	
U< below 30 V	On/Off	Off	
Overvoltage U> [%]	100...140 %	110 %	
Overvolt. blocking U>	On/Off	Off	
Overcurrent I> [%]	50...210 %	110 %	
Overcurr. blocking I>.	On/Off	On	
Undercurrent I< [%]	0...210 %	0 %	
Undercurr. blocking I<	On/Off	Off	
Neg. active power block.	On/Off	Off	
Control parameters > Compensation			
Compensation method	LDC/Z	LDC	
line drop compensation Ur	-25 to 25 V	0.0 V	
line drop compensation Ux	-25 to 25 V	0.0 V	
Z compensation	0...15 %	0.0 %	



Parameter	Setting range	Factory setting	Current setting
Z comp. limit value	0...15 %	0.0 %	
Configuration > Transformer data			
Primary voltage	0...9999 kV	0 kV	
Secondary voltage	57 to 123 V	100.0 V	
Primary current	0...10000 A	0 a	
Current transformer connection	Unknown; 1 A; 5 A	Unknown	
Transformer circuit	See [▶ Section 8.7.5, Page 97]	0 1PH	
Display kV / V	kV/V	V	
Display %/A	%/A	%	
Configuration > General			
Language	See [▶ Section 7.2.1, Page 48]	German	
Regulator ID	-	0000	
Baud rate	9.6 kilobaud; 19.2 kilobaud; 38.4 kilobaud; 57.6 kilobaud	57.6 kilobaud	
R/L pulse duration	0...10 s	1.5 s	
Operation counter	0...99999999	0	
Display dimming	On/Off	On	
Key lock	On/Off	On	
Function monitoring	On/Off	Off	
Delay function monitoring	0...120 min	15 min	
Motor runtime	0...30 s	0.0 s	
Manual/Automatic	Manual/Auto	Manual	
Local/Remote	Local/Remote	Local	
COM1 password	-	-	
Password duration	1...50 min	5 min	
Configuration > Parallel operation			
Parallel operation activation	On/Off	On	
Parallel operation method	Circulating reactive current; Master; Follower; Auto synchronization	Circulating reactive current	
Parallel operation group	None; Group 1; Group 2; Group 1 and Group 2	None	
CAN address	0...16	0	
Simplex mode blocking	On/Off	On	
Circulating reactive current sensitivity	0...100 %	0.0 %	



Parameter	Setting range	Factory setting	Current setting
Circulating reactive current blocking	0.5...40 %	20.0 %	
Master/follower current blocking	Blocking/Off	Blocking	
Parallel error delay	1...999 s	10 s	
Follower tapping direction	Standard/Swapped	Standard	
Max. tap difference	1...4	1	
Follower tapping without U_{meas}	On/Off	Off	
Configuration > User In/Outputs			
GPI 1 – X4:13	See [▶ Section 8.11, Page 116]	Off	
GPI 2 – X4:14		Off	
GPI 3 – X4:15		Off	
GPI 4 – X4:16		Quick Tap	
GPI 5 – X4:17		Desired value 2	
GPI 6 – X4:18		Desired value 3	
GPI 7 – X6:1		ParGroup1	
GPI 8 – X6:2	ParGroup2		
GPO 1 – X4:9		Off	
GPO 2 – X4:12		Off	
GPO 3 – X5:9		ParState	
GPO 4 – X5:12		ParError	
GPO 5 – X5:18		Undervoltage	
GPO 6 – X5:21		Overvoltage	
GPO 7 – X5:24		Overcurrent	
Configuration > LED selection			
LED1	See [▶ Section 8.12, Page 120]	GPI 1	
LED2		GPI 2	
LED3 yellow		Off	
LED3 green		Off	
LED4 yellow		Off	
LED4 red		Off	
Configuration - Tap position options			
Tap pos. capture	See [▶ Section 8.9, Page 109]	Off	
Analog Val. [%] Tap pos. min	0...100 %	0.0 %	
Analog Val. [%] Tap pos. max.	0...100 %	100.0 %	
Lowest tap position	-40...40	0	
Highest tap position	-40...40	19	



Parameter	Setting range	Factory setting	Current setting
Lower tap position blocking	-128...128	0	
Upper tap position blocking	-128...128	40	
Tap position limits blocking behavior	Off; Directional; Non-directional	Off	
Configuration > Set desired voltage level remotely.			
Set desired voltage level remotely	Off; 0/4...20 mA; potentiometer series	Off	
Analog value desired value min	0...100 %	0.0 5	
Analog value desired value max	0...100 %	100.0 %	
Minimum desired value	0 to 140 V	80.0 V	
Maximum desired value	0 to 140 V	140.0 V	
Info			
Info			
Measured values			
Calculated values			
LED test			
MIO card digital inputs			
MIO card digital outputs			
PIO card digital inputs			
PIO card digital outputs			
PIO X7 analog input			
Parallel operation			
Data on CAN bus			
Peak memory			
Default parameter			
Memory overview			
Event memory			

Table 44: Overview of parameters



13 Technical data

13.1 Display elements

Display	LCD, monochrome, graphics-capable 128 x 128 pixels
LEDs	15 LEDs for operation display and messages of which 4 LEDs are freely programmable (2x yellow, 1x yellow/green, 1x yellow/red)

Table 45: Display elements

13.2 Electrical data

Permissible voltage range	90...264 V AC 100...353 V DC U_N 100...240 V AC U_N 100...353 V DC
Permissible frequency range	50 / 60 Hz
Power consumption	12.5 VA

Table 46: Electrical data

13.3 Dimensions and weight

Housing (W x H x D)	198 x 310 x 135.5 mm
Door (W x H)	244 x 342 mm
Weight	6.8 kg

Table 47: Dimensions and weight

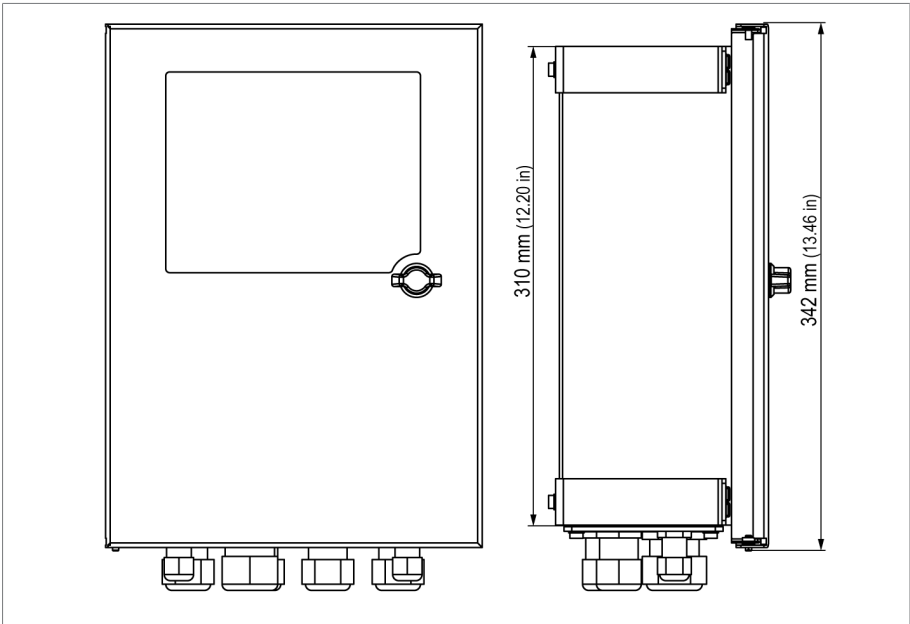

Figure 75: Front view and side view

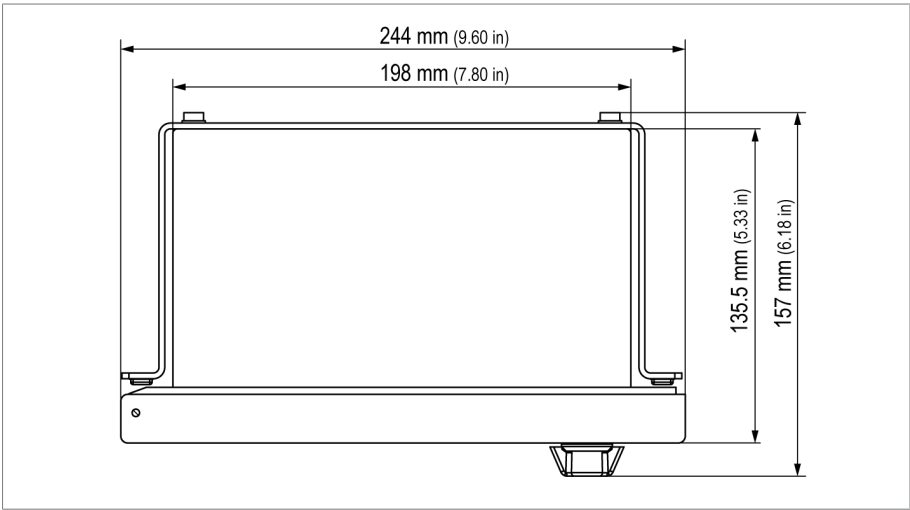

Figure 76: View from above with installed door

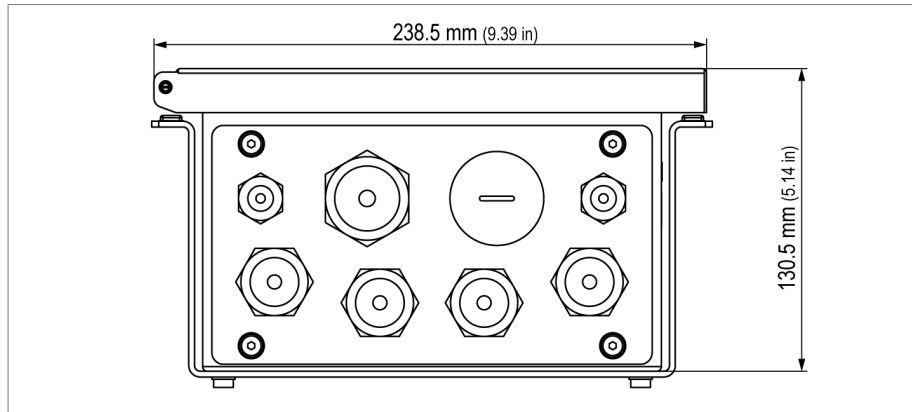

Figure 77: View from below without door

13.4 Ambient conditions

Operating temperature	-25°C...+70°C
Storage temperature	-40°C...+85°C

Table 48: Ambient conditions

13.5 Electrical safety

<p>IEC 61010-1 IEC 61010-2-030 IEC 61010-2-201</p>	<p>Safety requirements for electrical measurement and control and regulation equipment and laboratory instruments</p> <ul style="list-style-type: none"> ▪ Protection class 1 ▪ Overvoltage category III ▪ Contamination level 2 ▪ Measurement category III
IEC 61131-2	<p>Dielectric test with operating frequency 350 V AC...5870 V AC (depending on the operating voltage of the power circuit)</p>
IEC 60255	<p>Dielectric test with impulse voltage 5 kV, 1.2/50 μs</p>
VDE 0435	<p>Short-time current and long-term load capacity of current transformer inputs</p> <ul style="list-style-type: none"> ▪ 100 x I_n/1 s ▪ 2 x I_n/continuous

Table 49: Electrical safety



13.6 Electromagnetic compatibility

IEC 61000-4-2	Electrostatic discharges (ESD) 8 kV/15 kV
IEC 61000-4-3	Electromagnetic fields (HF) 20 V/m 80...3000 MHz
IEC 61000-4-4	Fast transients (burst) 6.5 kV
IEC 61000-4-5	Surge transient immunity 2 kV (outer conductor/outer conductor), 4 kV (outer conductor/ground)
IEC 61000-4-6	HF interference immunity (lines) 10 V, 150 kHz...80 MHz
IEC 61000-4-8	Power frequency magnetic field immunity 1000 A/m
IEC 61000-6-2	Immunity requirements for industrial en- vironments
IEC 61000-6-4	Emission standard for industrial environ- ments

Table 50: Electromagnetic compatibility

13.7 Environmental durability tests

DIN EN 60529	Determination of protection class for "protection against contact, ingress of foreign objects and water for electrical equipment" Level IP54
IEC 60068-2-1	Dry cold - 25 °C / 16 hours
IEC 60068-2-2	Dry heat + 70 °C / 16 hours
IEC 60068-2-3	Constant moist heat + 40 °C / 93% / 21 days
IEC 60068-2-30	Cyclic moist heat (12 + 12 hours) + 55 °C / 93% and + 25 °C / 95% / 6 cy- cles

Table 51: Environmental durability tests

13.8 Mechanical stability

IEC 60068-2-31	Drop and topple, unpacked 100 mm fall height
IEC 60068-2-32	Free fall, unpacked 250 mm fall height
IEC 255-21-1 Class 1	Bounce test
IEC 255-21-2 Class 1	Shock and bump test
IEC 255-21-3 Class 1	Seismic test

Table 52: Mechanical stability



Glossary

EMC

Electromagnetic compatibility

GPI

General Purpose Input

GPO

General Purpose Output

LDC

Line drop compensation

LED

Light-emitting diode

MR

Maschinenfabrik Reinhausen GmbH

R/L

Raise/lower



List of key words

A		D		G	
Analog input		Delay time T1	77	GPI	116
Calibrating	49	Delay time T2	79		
Analog value [%] Tap pos. max		Activating	79	H	
112		Deactivating	79	Highest tap position	112
Analog value [%] Tap pos. min		Desired value	72	highest tap position blocking limit	
111		Desired value	74	88	
Auxiliary supply	44	Device ID	60	High-speed return	84, 85
		Display contrast	47		
		Display dimming	64		
B				I	
Bandwidth	76	E		Indicator elements	
Calculation	76	Electromagnetic compatibility	39	Indicator elements	22
Visual display	77			LED	22
Baud rate	61	F		Info	122
		Factory setting	128, 138		
C		Fiber-optic cable		K	
Cable recommendation	38	Information about laying	39	Key lock	60
Calculated values	123	flush panel mounting	32	automatic	64
CAN bus	102	Follower			
Data	127	without measured voltage	108	L	
Cap rail clip	34	Follower tapping direction	105	Language	48
circulating reactive current	102	Follower tapping without Umeas	108	LED selection	120
Blocking	103	Function monitoring		Limit value	
Master/Follower current block-		Delay time	65	Limit value monitoring	80
ing	106	Suppress message	65	Overvoltage U>	83
Sensitivity	103	Function test		Undervoltage U<	80
COM1 password	69	Additional functions	52	Line drop compensation	
COM1 setting	61	Circulating reactive current		Inductive voltage drop	91
Compensation	89	blocking	56	Ohmic voltage drop	91
Z compensation	92	Circulating reactive current		Lowest tap position	111
Connection	37	sensitivity	55	lowest tap position blocking limit	
Contrast	47	Control functions	51	87	
Control parameter		Desired value 2	53	M	
Desired value	74	Desired value 3	53	Measured values	122
control parameters	72	Line drop compensation	53	Memory overview	129
Control response T1	78	Overvoltage U>	52	Motor runtime	66
		Parallel operation	55	Output relay	67
		Tap synchronization	57		
		Undervoltage U<	52		
		Z compensation	54		
		Function tests	50	N	
		LDC	53	Neg. active power flow	87
				NORMset	71

Maschinenfabrik Reinhausen GmbH

Falkensteinstrasse 8
93059 Regensburg

☎ +49 (0)941 4090-0

📠 +49(0)941 4090-7001

✉ sales@reinhausen.com

www.reinhausen.com

3550953/02 EN - TAPCON® 230 pro -

- 08/19 - Maschinenfabrik Reinhausen GmbH 2019

THE POWER BEHIND POWER.

